



Grade : 11 **G.C.E. (O/L) Practice Test - 2019** **32 E I**

Mathematics I **Time : Two Hours**

Name / Index no.

.....
 Invigilator's Signature

Important	Fox examiner's Use only		
	Question number	Marks	
<ul style="list-style-type: none"> ● The Question paper contains 8 pages. ● Answer all questions on the paper it self ● Use the given space to show methods. ● It is necessary to write relevant steps and correct units ● Part A Each question carries 2 marks ● Part B Each question carries 10 marks 	Part A	1-25	
	Part B	1	
		2	
		3	
		4	
		5	
	Total		
 Marked by	 Code number
 Checked by	 Code number
 EMF	 Code number
..... Chief Examiner	 Code number	

Part - A

● Answer all question on the paper it self

01. When a television set worth Rs. 50,000 is imported, 8% of the value is charged as the duty. Find the price of the television set after the duty is paid.

02. Simplify : $\frac{2}{3x} + \frac{5}{6x} - \frac{1}{x}$

03. Find the values of x and y in the figure.

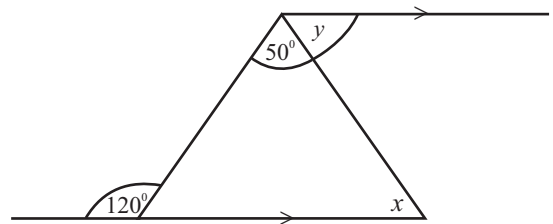

04. $\log_a 8 = 3$.

i. Express the above expression in index form.

ii. Find the value of a .

05. The length of the arc PQ of the sector is 11 cm. Find the perimeter of the sector.

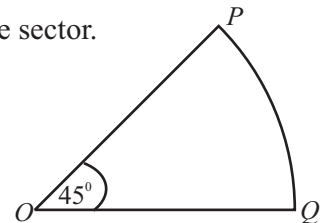

06. The least common multiple of two algebraic terms is $2a^2x$. One term is $2a$. Find the other term and underline the correct answer.

i. $2ax^2$

ii. $2x$

iii. a^2x

iv. a^2x^2

07. Express the shaded portion of the Venn diagram in set notation.

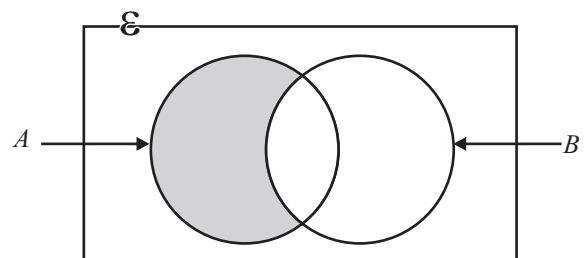

08. $PQRS$ is a parallelogram. $\hat{PRS} = 32^\circ$. Find the value of \hat{PQR} .

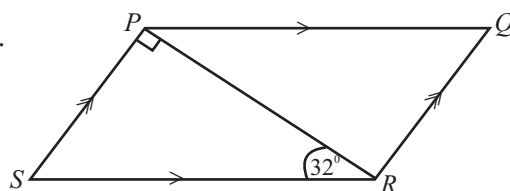

09. $3x^2 + x - 10 = (x+p)(3x-q)$.
Find the values of p and q .

10. 4.3 cm, 4.4 cm, 4.5 cm, 4.6 cm. From the above lengths, choose and write the approximate value for the side length of a square of area 20 cm^2 .

11. In the figure, $AD = DB$ and $\hat{ADE} = \hat{ABC}$.
i. Write the relationship between DE and BC .
ii. Find the length EC if, $AE = 5 \text{ cm}$.

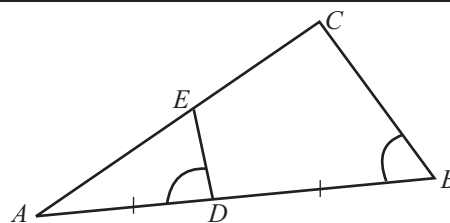

12. $\tan \theta = \frac{2}{3}$. Find $\sin \theta$. (Express the answer as a surd.)

13. Given that, $A = \begin{bmatrix} 2 & 0 \\ 4 & -1 \end{bmatrix}$ and $B = \begin{bmatrix} -1 \\ 0 \end{bmatrix}$ Find the matrix $2AB$.

14. Find the value of x in the figure.

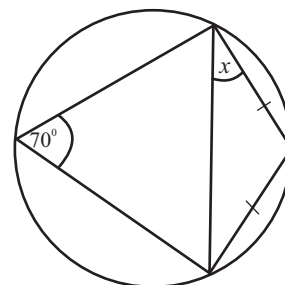

15. 8 men need 5 days to complete a task . But after working for two days, two workers stopped attending to work. Find the number of days taken by the reaming workers to do the whole task.

16. Put (✓) in front of the properties which are common both rhombus and square and put (✗) in front of proportion which are not common to both rhombus and square.

1. Diagonals bisect each other perpendicularly.	
2. The diagonals bisect vertex angles	
3. All vertex angles are equal.	

17. Solve the equation : $m^2 - 16 = 6m$.

18. In the figure, $AB \parallel CD$ and $AE = EC$. Name a pair of congruent triangles and state the case of congruency.

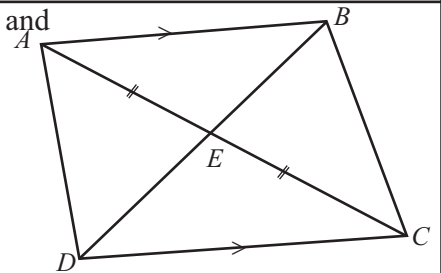

19. A card is picked at random from 10 identical cards numbered from 1 to 10. Find the probability a square number is mentioned on the card picked.

20. The perpendicular height and the volume of a right circular solid cylinder are 20 cm and 3080 cm^3 respectively. Find the radius of the base of the cylinder. (volume of a right circular cylinder of radius r and perpendicular height h is $\pi r^2 h$).

21. AOB is a diameter of the circle of centre O . AB is perpendicular to PQ . $AR = 2$ cm and $RB = 8$ cm. Find the length of the chord PQ .

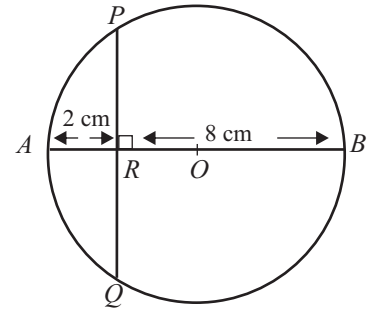

22. 3, 4, x , 10, 12, 12, 15, 19, 20, 22, 24. The above is a distribution of data arranged in ascending order. The inter quartile range of the distribution is 12. Find the value of x .

23. Represent the integers which satisfy the inequalities $x < 3$ and $x \geq -2$ on the number line.

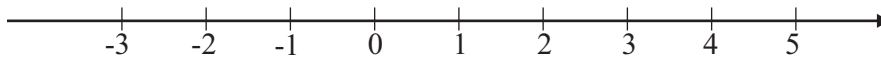

24. In the figure, AX is the bisector of \hat{BAC} . $\hat{ACB} = 55^\circ$ and $\hat{XAC} = 35^\circ$. Find the magnitude of \hat{AXC} .

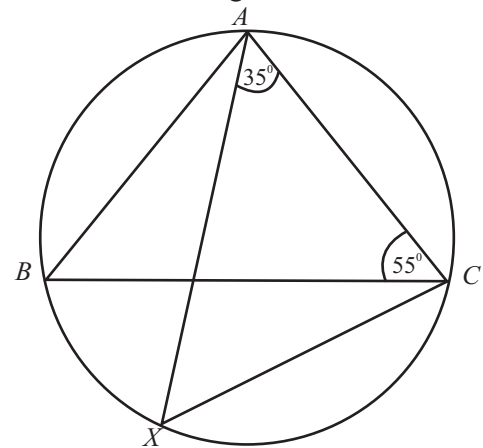

25. x and y are two towns 110 km apart. A vehicle started travelling from y towards x at a uniform speed of 60 kmh^{-1} . At the same time another vehicle started travelling from x towards y at a uniform speed of 50 kmh^{-1} . Find the time taken for the two vehicles to meet each other.

Part B

Answer all questions on the paper itself.

(01) Prices of coconuts, in a whole sale shop, are marked according to the sizes as small, medium and large.

i. $\frac{2}{5}$ of a stock of coconuts are large coconuts and $\frac{5}{8}$ of the remainder are medium sized coconuts.
What fraction of the whole stock is the medium sized coconuts?

ii. Express the number of small coconuts as a fraction of the total number of coconuts in the stock.

iii. If the difference between the number of large coconuts and the number of small coconuts in the stock is 350, find the total number of coconuts in the stock.

iv. The price of a large coconut is Rs. 10 more than price of a medium sized coconut and the price of a small coconut is Rs. 5 less than the price of a medium sized coconut. The cost of three coconuts, one from each type, is Rs. 110. Find the price of a medium sized coconut.

(02) $ABCDEFGG$ is a flower bed in a garden. $ABFG$ and $CDEF$ are squares and FBC is a sector.

i. Find the length of arc BC

ii. Find the perimeter of the flower bed.

iii. Find the area of the flower bed.

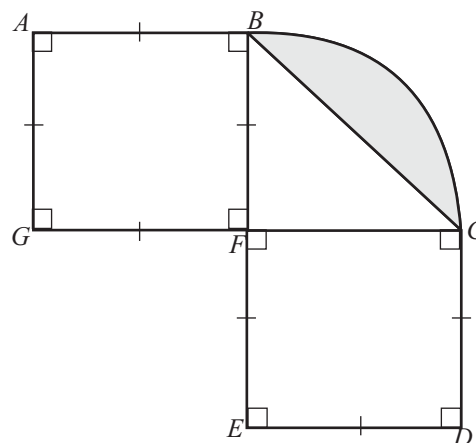

iv. A rectangular part is to be adjoined to the above flower bed, such that the area of it is equal to the area of shaded part and such that GF is one side of it. Sketch, in the figure, with measurements how the rectangular part should be adjoined.

(03) Randunu needs to obtain a loan of Rs. 250 000 to renovate his house. Following table shows how the interest is calculated for loans in two financial institutes.

Institute	Interest rate
<i>A</i>	16 % simple interest rate per annum.
<i>B</i>	15% compound interest rate per annum for loans over Rs. 200 000.

i. Find the interest that should be paid for a year if the loan is obtained from institute *A*.

ii. Find the total amount that should be paid at the end of the second year, if the loan is obtained from institute *A*.

iii. Find the total amount that should be paid to settle the loan, if it is obtained from institute *B*.

iv. Which is the more profitable institute for him to obtain the loan? Explain with reasons.

(04) A bag contains six identical balls numbered from 1 to 6. A ball is taken out at random, the number is noticed, and then another ball is taken out at random without replacing the first ball.

i. Represent the sample space of the above experiment on the grid.

ii. Enclose in the grid, the event, that, the sum of the two numbers obtained is greater than 7 and find its probability.

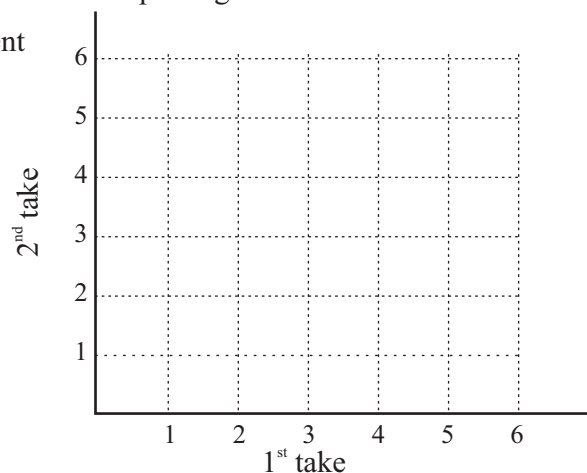

iii. Considering the event of getting a number greater than 4 as A and getting a number less than or equal 4 as B , complete the following tree diagram.

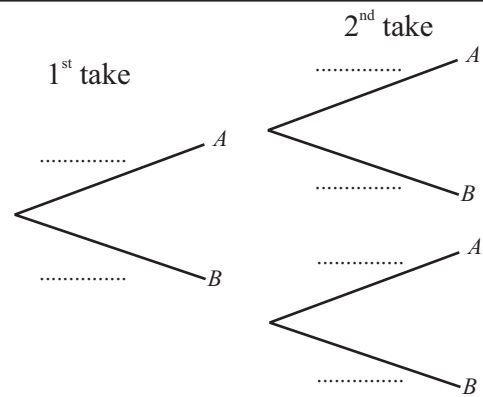

iv. Using the tree diagram, find the probability of getting a number greater than 4 at least once.

(05) The following is a cumulative frequency curve drawn to represent lengths of pieces of clothes bought from a cut piece shop.

i. Using the curve, find the median of the distribution.

Cumulative frequency

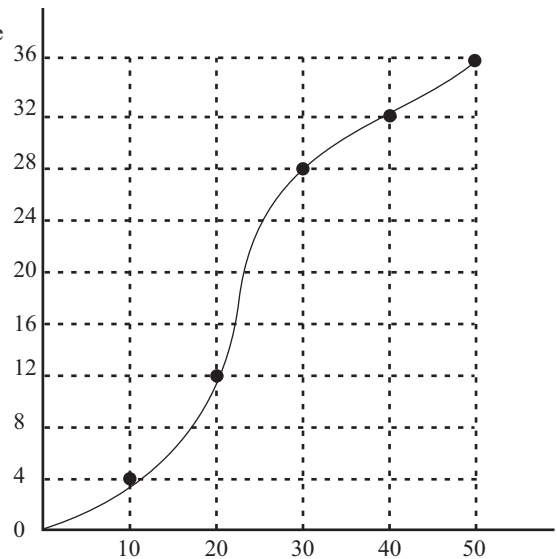

ii. Fill in the blanks of the following table.

Length at a piece (cm)	Number of pieces	Cumulative frequency
0 - 10	4	4
10 - 20	8	12
20 - 30	-----	28
30 - 40	-----	34
40 - 50	2	36

iii. Draw the histogram for the above distribution on the given pair of axes.

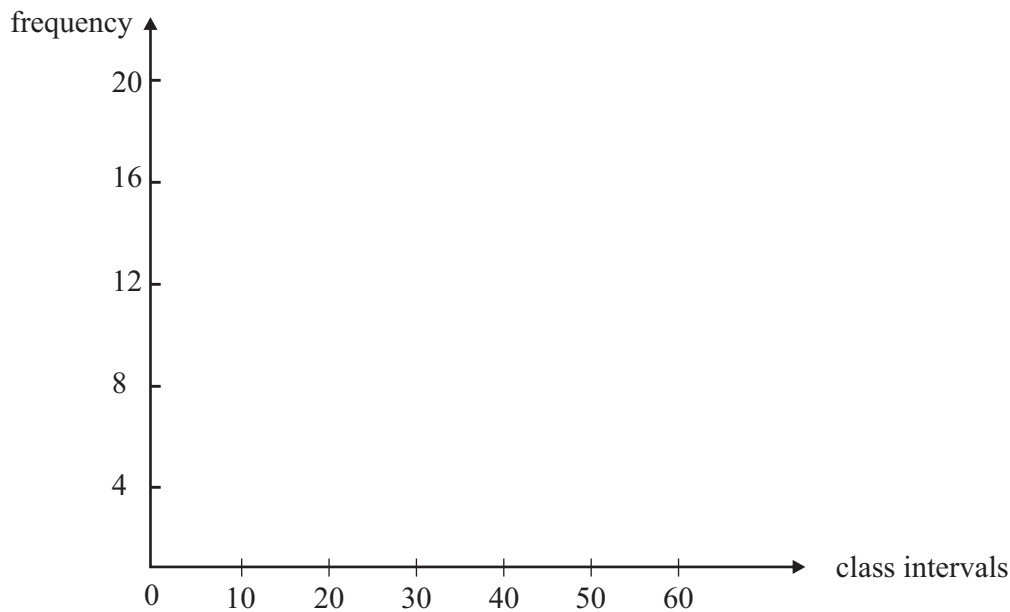

iv. Draw the frequency polygon.

* * *

Grade 11

G.C.E. (O/L) Practice Test - 2019

32 E II

Mathematics II

Time : Three Hours

Part A

Important :

- Answer 10 questions selecting 5 questions from part A and 5 questions from part B.
- Each question carries 10 marks.
- The volume of a sphere of radius r is $\frac{4}{3}\pi r^3$.
- The volume of right circular solid cylinder of base radius r and height h is $\pi r^2 h$.

Part A

Answer five questions only.

(01) Given below is an incomplete table of values prepared to draw the graph of the function $y = 2 + 4x - x^2$.

x	-1	0	1	2	3	4	5
y	-3	+2	5	5	+2	-3

- Find the value of y when $x=2$.
- Draw the graph of the function taking 10 small squares along both x and y axes as one unit. Using your graph,
- Write the interval of values of x which $y > 0$.
- Express the above function in the form $y = b - (x+a)^2$.
- Deduce co-ordinates of the point of intersection of the graph $y = x^2 - 4x - 2$ and x axis.

(02) The table shows information about the durations of telephone calls taken by 100 customers of a mobile network in a day.

Duration (minutes)	40-50	50-60	60-70	70-80	80-90	90-100	100-110
Number of customers	8	12	20	25	15	12	8

- What is the time interval which the most number of call durations fall into?
- Using the mid value of the class interval 70-80 as the assumed mean or otherwise, find the mean call duration to the nearest minute.
- If the call charge for a minute is Rs. 2.50, find the average total income the mobile network received from the above 100 customers in the day.

(03)(a) Sunimal bought 25 000 shares of a company at Rs. 30 per share. The company pays Rs. 4 per share as annual dividends. After a year, after getting dividends, he sold all the shares. The capital gain he received by selling shares was twice the dividend income he received. Find the price at which he sold a share.

(b) In the following year, he invested Rs. b to buy 500 shares of another company which pays, Rs. a per share as annual dividends. At the end of the year, he sold all the shares at Rs. P per share, and received a capital gain which is twice as the annual dividend income received in the year.
Show that $P = 2a + \frac{b}{500}$.

(04) AB is a vertical post erected on the horizontal ground. The top of the post B is tied down to the ground using a 30 m long wire, at the point C on the ground. The angle between the ground and the wire is $59^{\circ}32'$. DE is another vertical post of height 1.5 m. A wire is stretched from B to E . The distance between A and D is 10 m.

- Copy the diagram into your answer script and mark above information in it.
Using trigonometry,
- Find the height of the post AB .
- Find the angle between the wire BE and the horizontal plane.

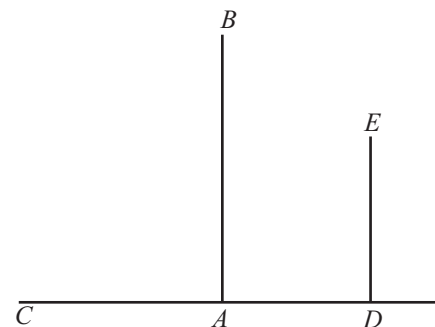

(05) The figure shows a cube of length $(x+2)$ and a cuboid with a square base of length $(x+1)$ and height $(x+5)$.

- If the volume of the cube is equal to the volume of the cuboid, show that x satisfies the equation $x^2 - x - 3 = 0$.
- Solve the above equation, by completing the square or any other method, and find the length of the cube to the nearest first decimal place. (Take $\sqrt{13} = 3.61$)

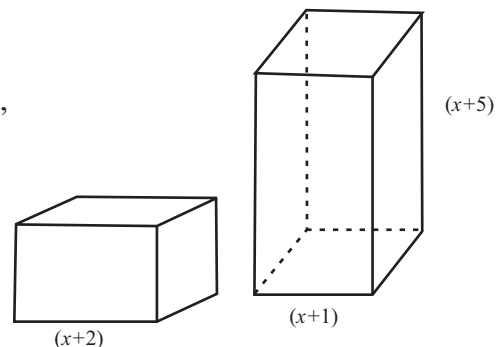

(06)a)

The price of a large mask - Rs. 1650
The price of a small mask - Rs. 600

The above is a notice displayed in a shop. The total income the owner of the shop received by selling masks of the above two types in a week is Rs. 48 750. The profit obtained by selling a large mask is Rs. 350 and the profit obtained by selling a small mask is Rs. 200. The total profit obtained by selling masks of the above two types during the week is Rs. 13 250.

- Using the above information, build up a pair of simultaneous equations, taking the number of large masks sold as x and the number of small masks sold as y .
- Solve the pair of equations, and find the number of large masks sold and the number of small masks sold during the week.

b) Write the equal integral values which satisfy inequalities, $y > 1$ and $x \leq 2$.

Part B

Answer five questions only.

- (07)a) An athlete practicing for a race on a 200 m track ran two laps on the first day, three laps on the second day, four laps on the third day, such that on every day after the first day, ran one lap more than the previous day.
- Write the distances he ran in the first four days in order, and write to which type of a progression do those distances belong.
 - Find the distance he ran on the 9th day.
 - Show that the total distance he ran in the first 11 days exceeds 15 km.
- b) The first and fourth terms of a geometric progression are 3 and 24 respectively. Show that there can be only one possible value for the common ratio of the progression.

(08) Using a straight edge with a cm/mm scale and a pair of compasses only,

- Construct the line segment $AB = 8$ cm.
- Mark point C on AB such that $AC = 5$ cm. Locate point D such that $CD = 4$ cm and $\hat{BCD} = 60^\circ$.
- Construct the circle which touches AB at C and passes through the point D .
- Construct another tangent to the circle from A and name the point of contact as E .
- Name an angle equal to \hat{BCD} .

(09) $PQRS$ is a parallelogram. The equilateral triangle PQT is drawn on the side PQ and the equilateral triangle SRW is drawn on the side SR .

- Copy the diagram and mark above data in it.
- Show that $\hat{WRQ} = \hat{SPT}$.
- Prove that $WQ = ST$.
- Prove that $SWQT$ is a parallelogram.

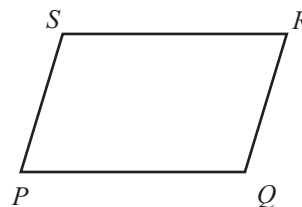

(10) Two solid metal spheres of radius r cm were melted and a solid metal sphere of radius and right circular solid metal cylinder of radius a and height h were made. There was no wastage of metal in the process.

- Show that $a = \frac{r}{4} \sqrt{\frac{19r}{h}}$.
- Using logarithms, find the value of a if, $r = 7$ cm and $h = 42$ cm.

(11) Three vertices of the equilateral triangle ABC lie on the circumference of a circle. AO produced meets the circle at D . BD produced and AC produced meet at E . prove that $AD = DC$.

(12) The following is an incomplete Venn diagram drawn to denote information about the ministries 88 employees have worked.

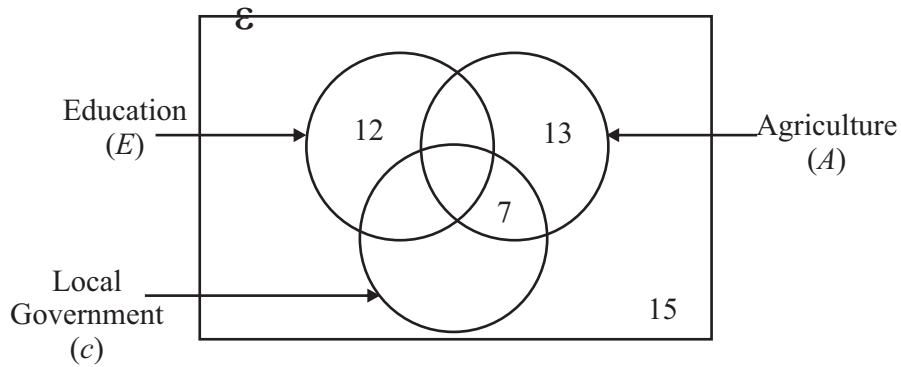

- The number of employees who have worked in the ministry of education and the ministry of local government is 15.
 - The number of employees who have worked in all three ministries is twice the number of employees who have worked in ministry of education and ministry of local governments only.
 - The number of employees who have worked in the ministry of education is 35 and the number of employees who have worked in the ministry of local government is 40.
- i. Copy the above Venn diagram and include the above information in it.
 - ii. How many employees have worked in at least two of the above ministries?
 - iii. Shade the region $E \cap (A \cup C)'$ in the Venn diagram.
 - iv. If an employee is selected from the above group at random, find the probability of the employee being a one who has worked in only one ministry.