

Name:-

Instructions:

- (i) Answer **four** questions in Part A, in the space provided.
(ii) Answer **three** questions in Part B.

Part A- Structured Essay

(01) (A) A student made a solution of equal amounts of Starch solution and Amylase solution. Then he got a drop from the solution after 2 minutes and placed it on a white porcelain tile and added a drop of Iodine onto the drop of mixture and observed the colour change. He continued the same procedure for about 20 minutes in 2 minute intervals. The following table was made according to the observations.

Time	2	4	6	8	10	12	14	16	18	20
Colour change	brown ↓ blue	brown ↓ blue	brown ↓ blue	brown ↓ blue	brown ↓ blue	brown ↓ blue	brown ↓ blue	brown ↓ brown	brown ↓ brown	brown ↓ brown

1. What are elements present in starch?
.....
2. Why was it only the brown colour of Iodine obtained during the time 16 – 20 min?
.....
3. Which compound was re solution during the time 16 – 20 min?
.....
- (B) 1. Which kingdoms belong to the domain Eukarya?
.....
2. Name a seedless non- flowering plant that belongs to the kingdom Plantae.
.....
3. Which invertebrate group contains an exoskeleton made up of chitin
.....
4. Name an organism belonging to the above group.
.....
- (C) Given below is a table showing acids of three different compositions prepared by group of students.

solution	A	B	C
water(ml)	7.5	5.0	2.5
Acid(ml)	2.5	5.0	7.5

1. When equal lengths of Magnesium strips were added into the above three acids separately, write the descending order of their reactivity in the above three acids.
.....
2. Explain the above order of reactivity considering the number of collisions that takes place between particles.
.....
.....

(D)

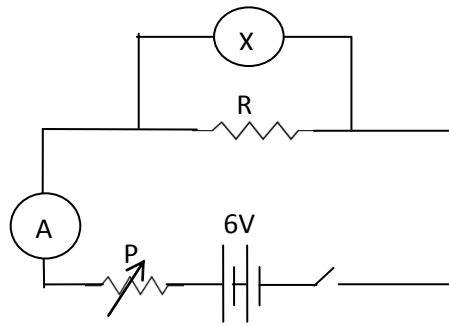

1. Name the device X shown in the above circuit.
.....
2. Which device of the circuit should be set up to increase the reading from 2 A to 3 A?
How should it be set up?
.....
.....
3. What is the value of R when the ammeter reading is 2 A?
.....
.....

(02) (A) Living matter is built up of Carbohydrates, Proteins, Lipids and Nucleic acids. In addition vitamins, minerals and water also help to build up living matter.

1. What is the basic unit of nucleic acids?
.....
2. Write the functions of nucleic acids.
.....
3. What is the mineral that affects mental development and intelligence?
.....

(B) The basic structural and functional unit of life is the cell. Following are two types of cells which can be observed through a light microscope.

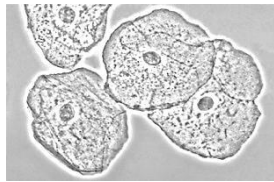

a

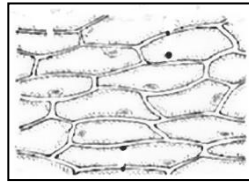

b

1. Name the letters denoting animal cell and the plant cell.
i. Plant cell ii. Animal cell
2. Name the membranous cellular organelle that is important in protein synthesis.
.....
3. Write one feature that helps to differentiate a plant cell from an animal cell.
.....

(C) A group of cells with a common origin that has been modified to perform a specific function in the body is known as a tissue.

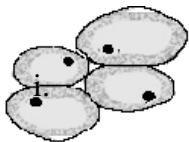

1. Name the following tissue
.....
2. What is the tissue that helps in increasing the diameter of the stem of a plant?
.....

3. a and b are two types of animal tissues.



a



b

i. Name an organ in which tissue 'a' can be observed.

ii. Write a difference between tissues 'a' and 'b'.

(D) 1. Write a living cell in the xylem tissue.

2. Write 2 types of cells in leaves where photosynthesis takes place.

3. How does the process of photosynthesis contribute to the existence of life?

(03) (A) A student made two mixtures as follows.

X – The mixture made by dissolving 10 g of NaOH in 250 cm³ of water.

Y - The mixture made by dissolving 10 g of CaCO₃ powder in 250 cm³ of water.

1. From the above mixtures, which one is the heterogeneous mixture?

2. a) How many moles of NaOH is used to make X mixture?

(Na = 23, O = 16, H = 1)

b) Find the composition of X mixture in n/v.

3. "Although jak glue is not soluble in water, it dissolves in kerosene oil". Explain this statement scientifically.

4. You are provided with a sugar solution. What is the solute of it?

(B) The raw material of salt production in Sri Lanka is sea water.

1. Name the method of producing salt.

2. What is the strategy used to eliminate the bitter taste of salt?

3. What is the reason for the insoluble property of salt?

(C) Following is a set up used to produce Oxygen gas.

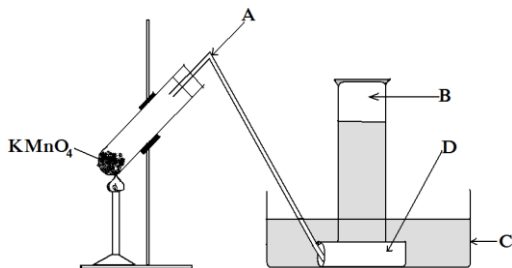

1. Name A,B,C,D

A -

B -

C -

D -

2. What is the above method of collecting gas known as?

3. What is the observation obtained when the residue that remains after all the Potassium Permanganate has decomposed, is let to react with water.

(04) (A) 1. Following is a type of mechanical wave demonstrated by a slinky. Name the type of wave.

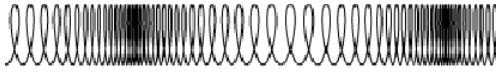

.....

2. Following is a representation of the position of particles of the above wave at one occasion.

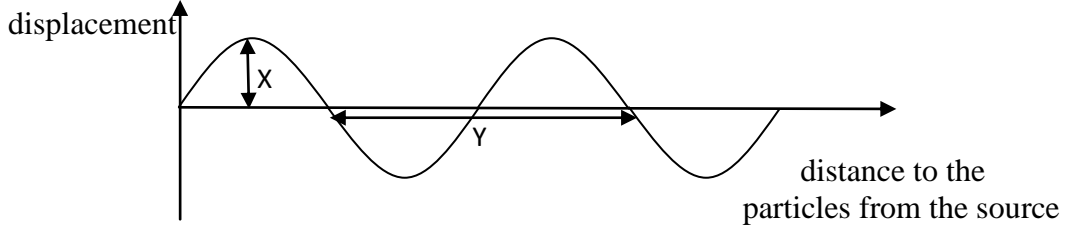

i. Name X and Y.

.....

ii. Find the frequency of this wave if it makes 12000 oscillations per minute.

.....

(B) A magnified, inverted image is formed on a screen when an object is kept in front of a convex lens.

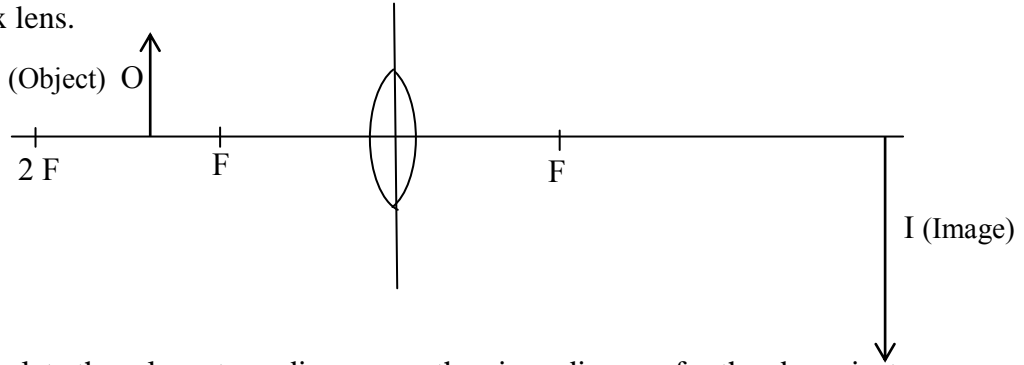

- Complete the relevant ray diagram on the given diagram for the above instance.
- How is an electromagnetic wave formed?

.....

3. Name the zones of the following electromagnetic spectrum.

Radio waves	Micro waves	X	visible rays	Y	X ray	Gama ray
-------------	-------------	---	--------------	---	-------	----------

X - Y -

(C) 1. Name an animal that makes use of echo sound.

2. Write an instance where ultra sound is made use by men.

.....

(D) When the unbalanced force acting on a stationary object is gradually increased, the object starts to move when the applied force is 4 N.

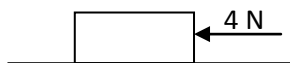

1. What is the limiting frictional force?

2. Will the force applied when the object is moving be greater than or less than the initial force?

3. Write a method to increase and decrease the frictional force.

i. Increase frictional force-

ii. Decrease frictional force-