

සියලු ම හිමිකම් ඇවිරිණි / முழுப் பதிப்புரிமையுடையது / All Rights Reserved]

ශ්‍රී ලංකා විභාග දෙපාර්තමේන්තුව ශ්‍රී ලංකා විභාග දෙපාර්තමේන්තුව ශ්‍රී ලංකා විභාග දෙපාර්තමේන්තුව ශ්‍රී ලංකා විභාග දෙපාර්තමේන්තුව ශ්‍රී ලංකා විභාග දෙපාර්තමේන්තුව
இலங்கைப் பரீட்சைத் திணைக்களம் இலங்கைப் பரීட்சைத் திணைக்களம் இலங்கைப் பரීட்சைத் திணைக்களம் இலங்கைப் பரීட்சைத் திணைக்களம் இலங்கைப் பரීட்சைத் திணைக்களம்
Department of Examinations, Sri Lanka Department of Examinations, Sri Lanka Department of Examinations, Sri Lanka Department of Examinations, Sri Lanka Department of Examinations, Sri Lanka
90 E I, II
Department of Examinations - Sri Lanka

අධ්‍යයන පොදු සහතික පත්‍ර (සාමාන්‍ය පෙළ) විභාගය, 2022(2023)
கல்விப் பொதுத் தராதரப் பத்திர (சாதாரண தர)ப் பரீட்சை, 2022(2023)
General Certificate of Education (Ord. Level) Examination, 2022(2023)

නිර්මාණකරණය, විදුලිය හා ඉලෙක්ට්‍රොනික තාක්ෂණවේදය
வடிவமைப்பும் மின் இலத்திரனியல் தொழினுட்பவியலும்
Design, Electrical & Electronic Technology

I, II
I, II
I, II

පැය තුනයි
முன்று மணித்தியாலம்
Three hours

අමතර කියවීමේ කාලය - මිනිත්තු 10 යි
மேலதிக வாசிப்பு நேரம் - 10 நிமிடங்கள்
Additional Reading Time - 10 minutes

Use additional reading time to go through the question paper, select the questions and decide on the questions that you give priority in answering.

Design, Electrical & Electronic Technology I

Instructions:

- * Answer all questions.
- * In each of the questions 1 to 40, pick one of the alternatives (1), (2), (3), (4) which is correct or most appropriate.
- * Mark a cross (X) on the number corresponding to your choice in the answer sheet provided.
- * Further instructions are given on the back of the answer sheet. Follow them carefully.

1. What is the standard line that is used to show hidden edges of a plan drawing?

- (1) _____
(2) _____
(3) _____
(4) _____

2. The number of tangent/tangents that can be drawn to a circle from an externally established point is/are

- (1) 1. (2) 2. (3) 4. (4) 360.

3. Select the wrong statement out of the following statements.

- (1) Value of sum of internal angles of a regular pentagon is equal to the value of the sum of internal angles of three triangles.
(2) There are same length two sides and same value two angles in an isosceles triangle.
(3) If two lines to be perpendicular to each other, the angle in between the two lines must be 90°.
(4) When draw concentric circles with different radiuses, the value of angles around the centre of circles are different from each other.

4.

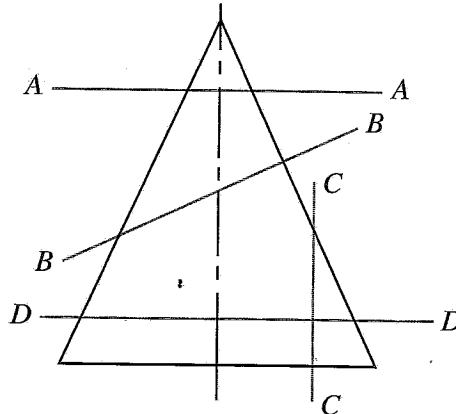

Few sectional planes on a cone are shown as A-A, B-B, C-C and D-D. Which sectional plane shows a shape of an ellipse when cut across?

- (1) A-A (2) B-B (3) C-C (4) D-D

5. The correct geometrical constructions that can be drawn with a specified length or a specified radius by joining two points on a flat surface are
- (1) one straight line and one arc.
 - (2) one straight line and two arcs.
 - (3) two straight lines and one arc.
 - (4) two straight lines and two arcs.

6.

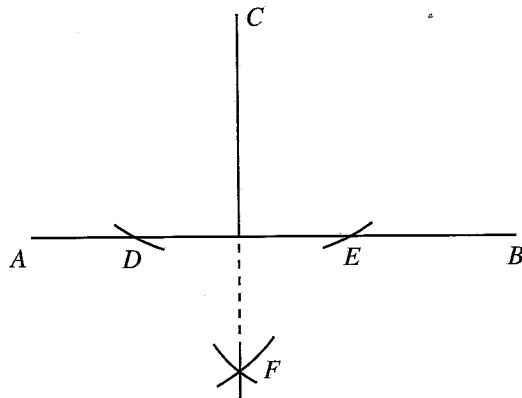

The geometrical construction shown in the above figure, is used

- (1) to draw a perpendicular to a straight line from an external point.
 - (2) to bisect a straight line.
 - (3) to bisect a straight line perpendicularly.
 - (4) to divide a straight line in a ratio.
7. In a resistor, in which the value is indicated by four colour bands, the third band is orange. In which range the value of that resistor would be?
- (1) 10Ω to 99Ω
 - (2) 100Ω to 999Ω
 - (3) 1000Ω to 9999Ω
 - (4) 10000Ω to 99999Ω
8. Which graph indicates the change of capacitive reactance (X_c) according to the capacitance (C) of a capacitor?

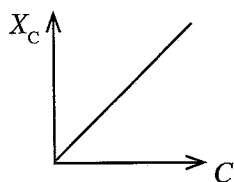

(1)

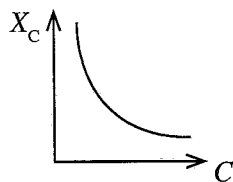

(2)

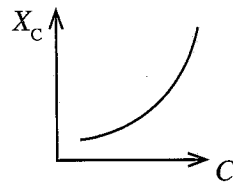

(3)

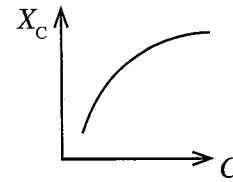

(4)

9. It has been mentioned as 273 in a capacitor, using capacitor code method. The value is
- (1) 270 pF.
 - (2) 273 pF.
 - (3) 2700 pF.
 - (4) 27000 pF.
10. To measure whether the voltage of a household socket outlet is in suitable range, the most appropriate equipment is
- (1) neon tester.
 - (2) test lamp.
 - (3) megger.
 - (4) multimeter.
11. According to the electrical engineering technology regulations, to control an electrical lamp of a house wiring circuit
- (1) the neutral cable should go through a switch.
 - (2) the live cable should go through a switch.
 - (3) the earth cable should go through a switch.
 - (4) neutral and live cables should go through a switch.

12. In wiring lamp circuits of domestic wiring circuits, the cables that should be used are
- (1) 1 mm², PVC PVC CU 1/1.13 cables.
 - (2) 1 mm², PVC cables.
 - (3) 2.5 mm², PVC PVC CU cables.
 - (4) 0.5 mm², TT Twin Twisted cables.
13. Miniature circuit breaker (MCB) mainly protects
- (1) the appliance used in the circuit.
 - (2) the residual current circuit breaker.
 - (3) the isolator.
 - (4) the cable installed from miniature circuit breaker to appliance.
14. To control a lamp from two places
- (1) only two SPST are needed.
 - (2) only one SPST and two SPDT are needed.
 - (3) only two SPDT are needed.
 - (4) only one SPDT and one DPST are needed.
15. What is the reason to connect a diode to the two sides of a coil in a relay?
- (1) To travel current only one way
 - (2) To neutralise the induced e.m.f. generated by stopping the current flowing through the relay coil
 - (3) To neutralise the induced e.m.f. generated in the appliance connected to the coil
 - (4) To rectify the induced e.m.f. generated in the coil
16. The current transformers are used to
- (1) get voltage readings.
 - (2) measure frequency.
 - (3) measure power factor.
 - (4) measure alternative current.

17.

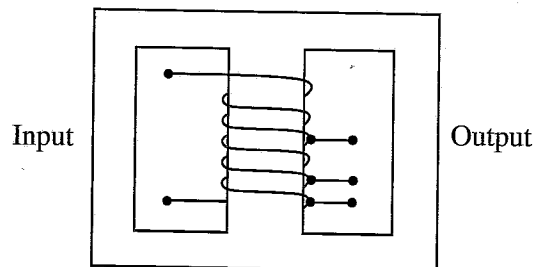

Above figure illustrates

- (1) a step up transformer.
 - (2) a step down transformer.
 - (3) an auto transformer.
 - (4) a current transformer.
18. Numbers of diode needed to assemble a bridge rectifier is
- (1) 1.
 - (2) 2.
 - (3) 3.
 - (4) 4.
19. Smoothing capacitor is needed for a power supply, which converts alternative voltage to direct current voltage. But why a capacitor is **not** needed for lead-acid battery charger?
- (1) As there is no need to smpoth direct current voltage
 - (2) Because the plates inside the battery act as a capacitor
 - (3) Because a variable direct current voltage is needed to charge the battery
 - (4) Because a variable voltage is needed to react the chemicals used for a battery
20. What is the device which can obtain an alternative voltage drop without a power loss?
- (1) Resistor
 - (2) Inductor
 - (3) Capacitor
 - (4) Diode

21. What is the correct symbol for a light emitting diode (LED)?

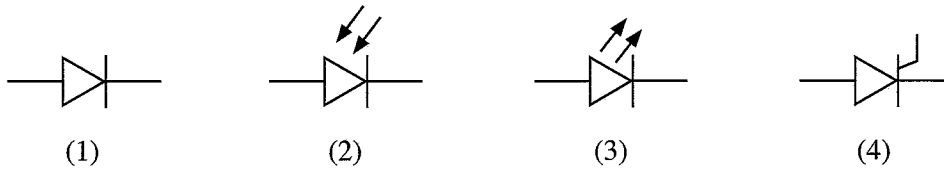

22. A multimeter is selected to measure resistance to test a rectifying diode. The black probe is connected to the anode of the diode and the red probe is connected to the cathode of the diode. Out of the following readings, what should be the multimeter reading, if the diode was an ideal diode?

- (1) 0 Ω
- (2) 60 Ω
- (3) 100 kΩ
- (4) ∞ Ω

23. What is the resistance reading, when the indicator is shown as below in a multimeter display?

- (1) 7 Ω
- (2) 70 Ω
- (3) 700 Ω
- (4) 7000 Ω

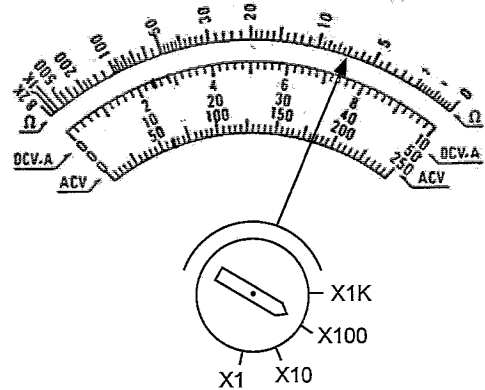

24. What is the **false** statement regarding the circuit given below?

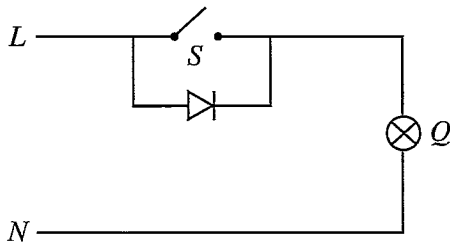

- (1) One half of the curve of alternative voltage is cut off when the *S* switch is opened.
- (2) Luminance of the *Q* lamp light increases when the *S* switch is closed.
- (3) The *Q* lamp gets a dim light when the *S* switch is opened and the diode direction is changed.
- (4) The luminance of *Q* lamp light increases when the *S* switch is turned off and the diode direction is changed.

25. What is the figure which correctly shows the transistor ends?

B – base *C* – collector *E* – emitter

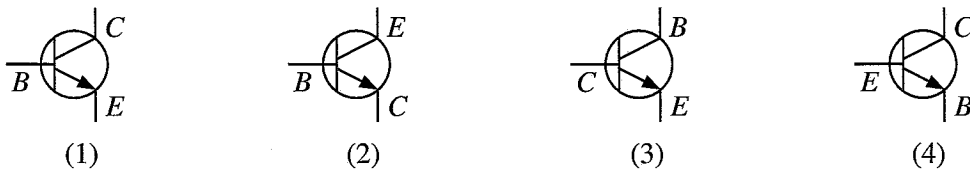

26. The factors needed for an NPN transistor to be on operational status is

- (1) forward biased, base-emitter junction and reversed biased, base-collector junction.
- (2) reversed biased, base-emitter junction and reversed biased, base-collector junction.
- (3) forward biased, base-emitter junction and forward biased, base-collector junction.
- (4) reversed biased, base-emitter junction and forward biased, base-collector junction.

27. A **disadvantage** of a transistor switch with reference to a normal switch is

- (1) operating without electric spikes.
- (2) the ability to operate in very high speed.
- (3) the ability to control with a very small voltage.
- (4) the existence of a small resistance when the switch is closed.

28. In which region of a transfer characteristics curve does a transistor work as a A class small signal amplifier?
 (1) Active region (2) Depletion region
 (3) Saturation region (4) Cut off region

29. What is the correct statement which shows the transistor current gain in a common emitter configuration?
 (1) $\frac{I_C}{I_E}$ (2) $\frac{I_B}{I_C}$ (3) $\frac{I_C}{I_B}$ (4) $\frac{I_E}{I_B}$

30. What is the graph which shows the change of collector current (I_C), in reference to the base current (I_B) in a transistor when a load is connected to the collector?

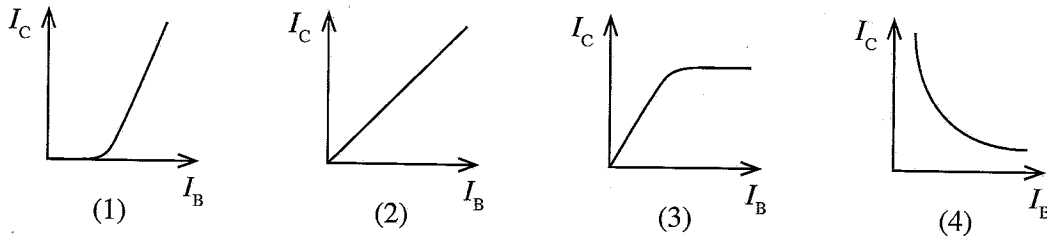

31. What ratio/ratios should be increased to develop the power gain of a signal, when amplifying a signal?
 (1) High frequency voltage (2) Voltage and current
 (3) Current (4) Low frequency voltage

32. Few single transistor amplifiers are connected in series when, assembling a public addressing amplifier. What is the reason for the total amplification gain to be much lesser than the multiplication of individual gain of each stage?
 (1) The internal resistance of each stage becomes a load to the previous stage.
 (2) The signal gets distorted when travelling through number of stages.
 (3) The internal resistance of each stage becomes a load to the next stage.
 (4) The power loss in resistive components used in the amplification stages.

33. What is the value when 10111_2 is converted to a decimal value?
 (1) 21 (2) 22 (3) 23 (4) 24

34. What should be the supply voltage for a 74 series TTL, integrated circuit?
 (1) 3 V (2) 5 V (3) 12 V (4) 18 V

35. How many AND and OR gates with two inputs are needed to obtain the connection, $Y = AB + CD + E$?
 (1) Two AND gates and two OR gates
 (2) Two AND gates and three OR gates
 (3) Three AND gates and two OR gates
 (4) Three AND gates and three OR gates

36. What is the correct truth table for the output of the logic circuit shown in the figure?

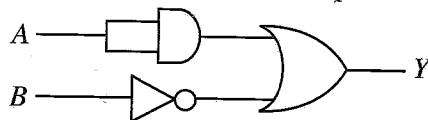

(1)

A	B	Y
0	0	1
0	1	0
1	0	1
1	1	1

(2)

A	B	Y
0	0	0
0	1	0
1	0	0
1	1	1

(3)

A	B	Y
0	0	1
0	1	1
1	0	1
1	1	0

(4)

A	B	Y
0	0	0
0	1	1
1	0	0
1	1	1

37. What logic circuit is represented by the figure?

- (1) S-R type flipflop
- (2) J-K type flipflop
- (3) D type flipflop
- (4) T type flipflop

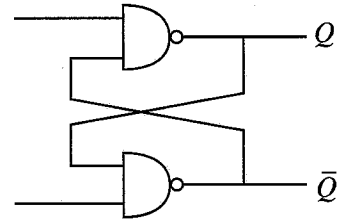

38. A few components of the electromagnetic spectrum is shown below. What would be the frequency range or ranges used for television remote control, if D and E are considered to represent visible light frequency range and ultraviolet frequency range (UV) respectively.

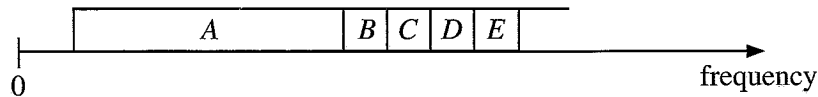

- (1) A and B
 - (2) A and C
 - (3) B
 - (4) C
39. The law which explains the operational principle of a motor is
- (1) Ohm's law.
 - (2) Fleming's Left hand law.
 - (3) Fleming's Right hand law.
 - (4) Joule's law.
40. What is the motor type used for ceiling fan?
- (1) Universal motor
 - (2) Synchronous motor
 - (3) Series wound motor
 - (4) Induction motor

**

සියලු ම හිමිකම් ඇවිරිණි / முழுப் பதிப்புரிமையுடையது / All Rights Reserved

ශ්‍රී ලංකා විභාග දෙපාර්තමේන්තුව ශ්‍රී ලංකා විභාග දෙපාර්තමේන්තුව ශ්‍රී ලංකා විභාග දෙපාර්තමේන්තුව ශ්‍රී ලංකා විභාග දෙපාර්තමේන්තුව ශ්‍රී ලංකා විභාග දෙපාර්තමේන්තුව
 இலங்கைப் பரீட்சைத் திணைக்களம் இலங்கைப் பரීட்சைத் திணைக்களம் இலங்கைப் பரීட்சைத் திணைக்களம் இலங்கைப் பரීட்சைத் திணைக்களம் இலங்கைப் பரීட்சைத் திணைக்களம்
 Department of Examinations, Sri Lanka Department of Examinations, Sri Lanka Department of Examinations, Sri Lanka Department of Examinations, Sri Lanka Department of Examinations, Sri Lanka
 ශ්‍රී ලංකා විභාග දෙපාර්තමේන්තුව ශ්‍රී ලංකා විභාග දෙපාර්තමේන්තුව ශ්‍රී ලංකා විභාග දෙපාර්තමේන්තුව ශ්‍රී ලංකා විභාග දෙපාර්තමේන්තුව ශ්‍රී ලංකා විභාග දෙපාර්තමේන්තුව
 இலங்கைப் பரීட்சைத் திணைக்களம் இலங்கைப் பரීட்சைத் திணைக்களம் இலங்கைப் பரීட்சைத் திணைக்களம் இலங்கைப் பரීட்சைத் திணைக்களம் இலங்கைப் பரීட்சைத் திணைக்களம்
 Department of Examinations, Sri Lanka Department of Examinations, Sri Lanka Department of Examinations, Sri Lanka Department of Examinations, Sri Lanka Department of Examinations, Sri Lanka

90 E I, II

අධ්‍යයන පොදු සහතික පත්‍ර (සාමාන්‍ය පෙළ) විභාගය, 2022(2023)
 கல்விப் பொதுத் தராதரப் பத்திர (சாதாரண தர)ப் பரீட்சை, 2022 (2023)
 General Certificate of Education (Ord. Level) Examination, 2022 (2023)

නිර්මාණකරණය, විදුලිය හා ඉලෙක්ට්‍රොනික තාක්ෂණවේදය I, II
 வாடிவமைப்பும் மின் இலத்திரனியல் தொழினுட்பவியலும் I, II
 Design, Electrical & Electronic Technology I, II

Design, Electrical & Electronic Technology II

- * Answer *five* questions including the *first* question and *four* other selected questions.
 * Question No.1 carries **20** marks and each of the other questions carry **10** marks.

1. (i) The following figure shows an isometric view of an object.
 (The figure is not drawn to a scale)

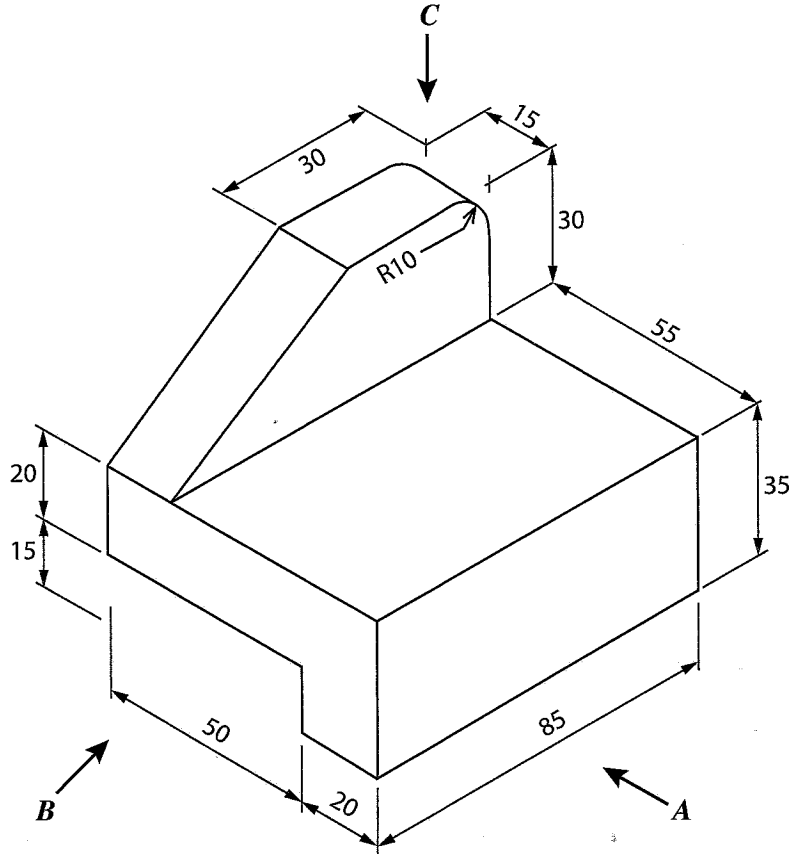

(All dimensions are in millimeters)

According to the above isometric view, draw the followings in third angle orthographic projection as per given measurement. The scale to be used is 1:1.

- (1) Front elevation by looking at arrow *A*,
 - (2) Side elevation by looking at arrow *B*,
 - (3) Plan by looking at arrow *C*.
- (ii) Construct a tangent to a circle with 30 mm radius from an external point of 90 mm distance to the center of circle.

2. The following figure illustrates the schematic diagram of a consumer unit of domestic electric installation consumed 30 A, 230 V electric supply.

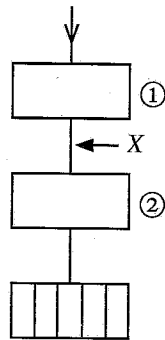

- (i) Mention the devices that should be in the places ① and ② of the above diagram.
- (ii) Mention the name and specifications of the cable used in X.
- (iii) Draw a suitable circuit diagram of a domestic electrical installation which is used to control the lamp of a staircase in two places including this schematic domestic electric installation diagram. Name the parts.

3. The following figure illustrates an electromagnetic assembly which can be used for a drawer lock.

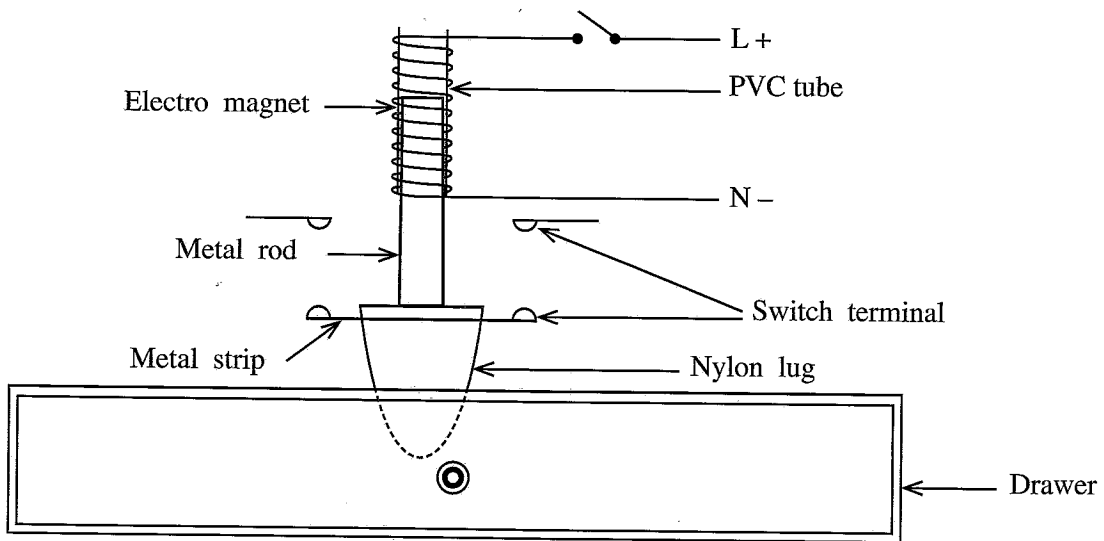

- (i) Write **three** properties of magnetic flux lines.
- (ii) Draw magnetic flux lines of the electro magnet, when the switch is activated, and the drawer can be opened by lifting the Nylon lug.
- (iii) Draw a self holding circuit to open and hold this lock using normally open (N.O) and normally close (N.C) two push button switches. Use the switch terminals shown in the figure.

4. Consider the following circuit with two resistors and 12 V electric source.

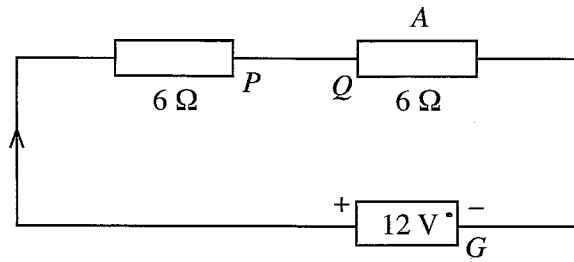

- (i) Calculate the current flowing through this circuit.
- (ii) Calculate the value of the **two** equal resistors connected to reduce the current flowing through this circuit up to 500 mA.
- (iii) What is the value of V_{PG} when the circuit is disconnected in place Q ?
- (iv) A is an appliance which is activated by 8 V and need 500 mA. Calculate the value of the resistor which should be connected in series to the appliance.

5. The following figure illustrates a temperature sensitive switch used transistors.

- (i) Does the L lamp light up when the temperature is increasing or decreasing. Describe.
- (ii) What is the value of V_{CE} when the lamp is light up in above (i)?
- (iii) Explain the action of NTC .
- (iv) What is the function of variable resistor R ?

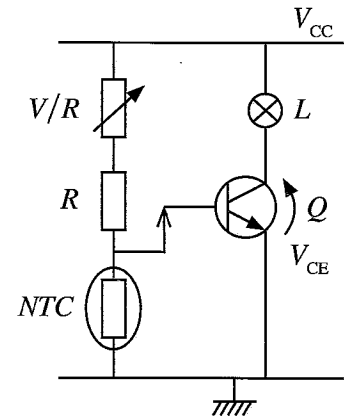

6. The following figure illustrates a simple rectifier circuit.

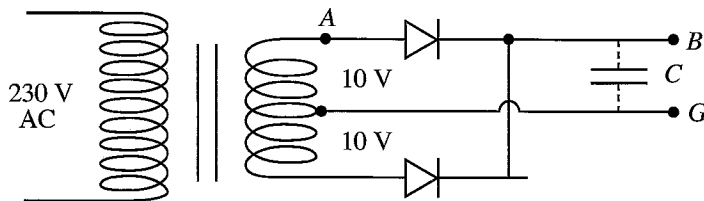

- (i) Which value of the alternative voltage is measured in A relative to G ?
- (ii) Draw the wave shape of the voltage in B without C capacitor.
- (iii) What is the direct current voltage in B with C capacitor?
- (iv) The figure illustrates two wards named as A and B of a hospital. Access lane and lanes to the two wards light up by L Lamp which is controlled at three places. Describe how X-OR gates can be used for the above control circuit referring to, truth tables.

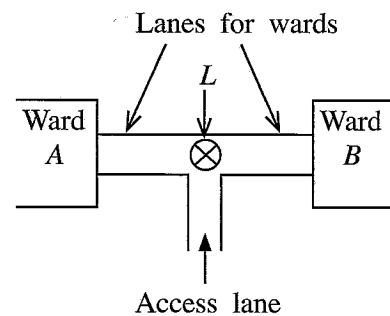

7.

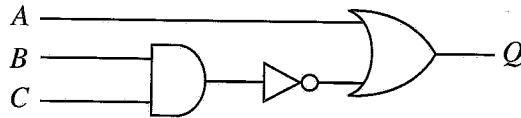

- (i) Complete the following truth table in your answer book according to the logic gate circuit illustrated above.

<i>A</i>	<i>B</i>	<i>C</i>	<i>Q</i>
1	0	1
0	1	0
0	1	1

- (ii) One gate can be used instead of **two** gates in logic gate circuit illustrated above (i). Name **two** removable gates and the gate can be used instead of two gates.
- (iii) Describe **two** advantages of designing a logic gate circuit using minimum number of gates.
