



JAFFNA HINDU COLLEGE

1st Term Evaluation Exam - 2022

Grade :- 8

Science

Time : 2.00 Hours

Name / Index No :

Part I

01. Given below are several diseases caused by micro organisms. Select the correct micro organism relevant to the disease

- | | |
|-----------------------|----------------------------|
| 1. Pityriasis - fungi | 2. Polio - bacteria |
| 3. leprosy - virus | 4. tuberculosis – protozoa |

02. Select the answer that includes only invertebrates

1. Leech, Snail, Dragonfly, Python
2. Cock, Dog, Snake, Bat
3. Spider, Sea anemone, Dragonfly, Bivalves
4. Bat, Beetle, Sea anemone, Butterfly

03. The non- metal with electrical conductivity is,

- | | | | |
|-----------|------------|------------|---------|
| 1. Carbon | 2. Mercury | 3. Sulphur | 4. Lead |
|-----------|------------|------------|---------|

04. Out of the following statements select the most suitable statement regarding micro - organism?

1. A hand lense can be used to observe micro - organisms
2. Micro - organisms are uni - cellular organisms
3. Micro - organisms cannot be seen with the naked eye
4. All the micro - organisms cause diseases to man

05. What are the elements in Calcium Carbonate?

- | | |
|-----------------------------|------------------------------|
| 1. Calcium, Carbon, Oxygen | 2. Calcium, Carbon, Hydrogen |
| 3. Carbon, Oxygen, Hydrogen | 4. Carbon, Sodium, Calcium |

06. Select the correct statement

1. Density is the volume of unit mass
2. Distilled water means cooled water after boiling up to the boiling point.
3. Density is a constant value for pure substances.
4. The purity of solids, liquids and gases cannot be determined by finding their densities.

07. Which animal does not belong to the group of Aves?

- | | | | |
|--------|---------|--------|-----------|
| 1. Bat | 2. Swan | 3. Owl | 4. Parrot |
|--------|---------|--------|-----------|

08. Plants with underground stems are,

- | | |
|-----------------------------------|---------------------------------|
| 1. Ginger, corn, leeks. | 2. Corn, turmeric, sweet potato |
| 3. Sweet potato, turmeric, potato | 4. Potato, turmeric, ginger |

09. Some of the statements about musical tones are given below

- A. It will never be oppressive
- B. It will be rhythmical play
- C. It is used to promote the quality of life

The correct statements from the above are,

- | | | | |
|------------|------------|------------|------------------|
| 1. A and B | 2. B and C | 3. A and C | 4. All A,B and C |
|------------|------------|------------|------------------|

10. Select the answer that does not match with the phenomena

- 1. Transpiration – Stomata
- 2. Storage of food – tuberous root
- 3. Photosynthesis – Leaf
- 4. Absorption of water and minerals – Aerial roots

(10 x 2 = 20 Marks)

If the following statements are correct put a tick (✓) and if wrong put a cross (x)

- | | |
|--|---------|
| 11. Cassowary is a bird which cannot fly | () |
| 12. Copper sulphate is a pure compound | () |
| 13. Xylophone is an instrument that produces sound by vibrating bars | () |
| 14. Guava leaves are on alternate sides of the stem | () |
| 15. Golden jewellery get damaged, when they are touched with Mercury | () |

(5 x 2 =10 Marks)

Select the suitable answer for part "A" from part "B"

A

B

- | | |
|---|---------------|
| 16. Have external ear lobes | a) Bee |
| 17. Leaves with mosaic disease | b) Sand paper |
| 18. leaves reduced to spines | c) Loris |
| 19. Has a thick texture | d) Papaw |
| 20. Sound is produced by the fast motion of their wings | e) Cactus |

(5 x 2 = 10 Marks)

PART 11

Answer all questions

1.

A. A group of student in grade 8, sprayed few drops of water on a slice of bread and kept it few days for the growth of micro-organisms. Then they observed a part of it under the compound microscope.

1) Name the group of micro-organisms that they observed under compound microscope?

.....

(1Mark)

2) Name the person who observed micro-organisms for the first time?

.....

(1 Mark)

3) What are the factors required for growth of microorganisms?

.....

.....

(2 Marks)

4) Write 02 harmful impacts of microorganisms?

.....

.....

(2 Marks)

5) Name the activity of micro-organisms on food items containing following types of nutrients.

a) Lipid containing food -

b) Sugar containing food -

c) Protein containing food -

(3 Mark)

B. The following activity is done by grade 8 students to observe the activity of micro - organisms.

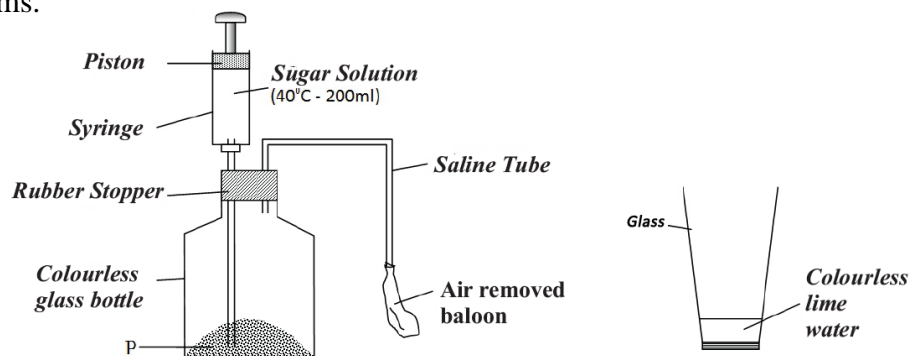

1. What is the micro – organism used as “P”?

.....

(1 Mark)

2. What is the procedure which can be taken to enter the sugar solution into the bottle?
.....
(1 Mark)

3. What is the method used by the student to speedup the microbial activity?
.....
(1 Mark)

4. Mention the observation of the following after few minutes.
a) Inside the bottle.
b) Of the balloon
(2 Mark)

5. After removing the saline tube, the was inserted in to the lime water.
a) What could be the observation?
(1 Mark)
b) What could be the released gas according to the above observation?
.....
(1 Mark)

(Total- 16 Marks)

2.

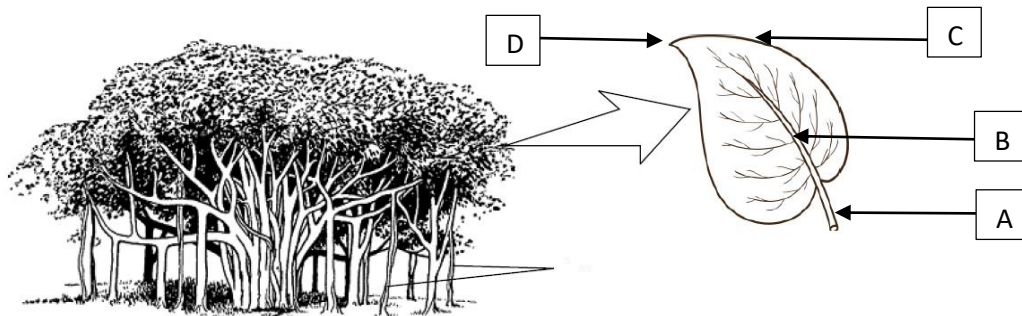

1. Lable the Parts from A - D ?
.....
.....
(2 Marks)

2. What is the **main** function of a plant leaf?
.....
(1 Mark)

3. What is the special root present in the given plant?
.....
(1 Mark)

4. Write the function of given
a) Climbing root
b) Stilt root
(2 Marks)

5. Give one example for each of the following

- a) Reproduced by stolon
- b) Stored foods in the adventitious roots
- c) stored water in the stem
- d) Plant which done propagation by roots

(2 Marks)

6. These plant leaves have thick and shiny surfaces.

a) Name the process which can be minimize through this adaptation?

.....
(1 Mark)

b) Write 2 any other adaptation of plants show to minimize the above mentioned process?

.....
.....
(2 Mark)

(Total - 11 Marks)

3. Below diagrams show some animals which are used for animal classification.



A

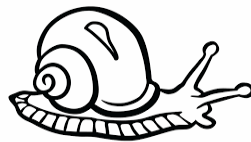

B

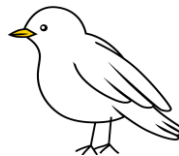

C

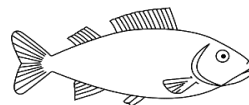

D



E

1. What do you mean by " Classification of Organisms"?

.....
(1 Mark)

2. Classify the above animals as vertebrates and invertebrates.

.....
.....
(2 Marks)

3. Write a similarity and dissimilarity between Organisms of group "C" and "D"?

.....
.....
(2 Marks)

4. Which type of symmetry can be observed in animal "A"?

.....
(1 Mark)

5. What is the locomotive organ of animal "B"?

.....
(1 Marks)

6. The animal "E" of the group which is belong is named as segmented worms.

a) What is the reason for naming them as "segmented worms"?

.....
(1 Mark)

b) Write an important of living that creature in a crop – land?

.....
(1 Mark)

7. Select the animals from above for following characters.

a) Gills for respiration

b) Forelimbs are modified into wings

(2 Marks)

(Total – 11 Marks)

4. A group of grade 8 students have done an experiment with their teacher at the lab using Nitrogen dioxide gas as follows.

A)



1. What is the observation in the above activity?

.....
(1 Mark)

2. What is the reason for the above observation?

.....
(1 Mark)

3. Why Nitrogen dioxide gas is used in it?

.....
(1 Mark)

4. Draw the pattern of organization of particles in the Nitrogen dioxide gas.



(1 Mark)

B) Name the following elements.



A



B

A :

B :

(2 Marks)

C) Below experiment has designed by the group of grade 8 students with a help of teacher.

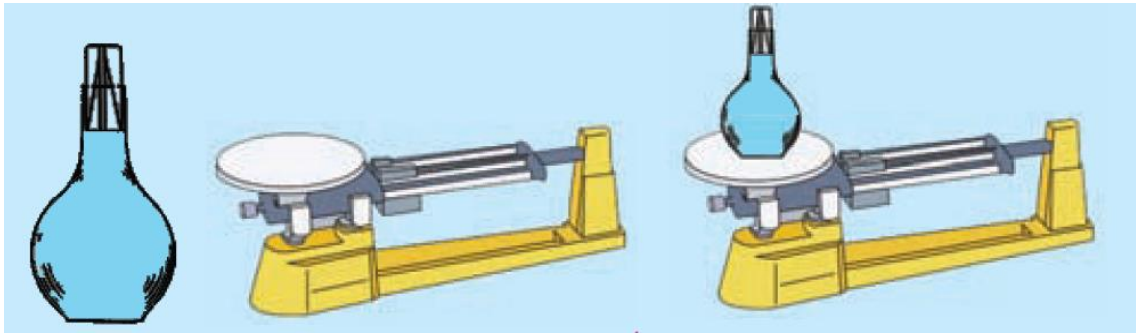

1. What is called the density of a substance?

.....

(1 Mark)

2. Write another name for the density bottle ?

.....

(1 Mark)

3. What instruments should be taken to find out the purity of water.

.....

(1 Mark)

4. Explain how you find out the purity of distilled water using those instruments?

.....

.....

(2 Marks)

(Total – 11 Marks)

A. Given below is a structure of a musical instrument which can be made easily

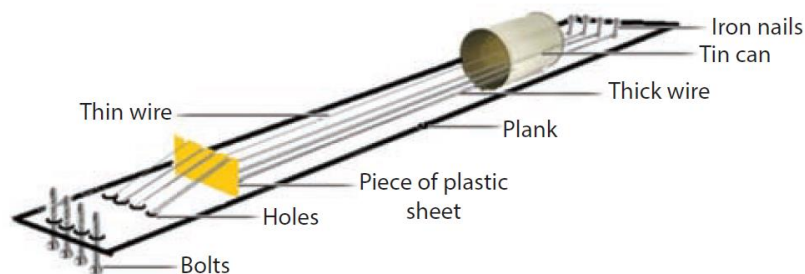

1. How does this musical instrument produce sound?

.....

(1 Mark)

2. Name another two musical instruments that produce sound like that?

.....

(1 Mark)

3. Write how the frequency of the sound is made by the musical instruments changes in each of the following instances.

a) When the vibrating length of the strings get decreased.

.....

b) By increasing the tension of strings

.....

(2 Marks)

4. a) Write two other ways, how sound is produced from musical instruments.

.....

(1 Mark)

c) Write one example for each?

.....

(1 Mark)

B. A group of grade 8 students displayed some instrument in the laboratory to check the frequency of vibrations. Diagram of that source of sound is given below.

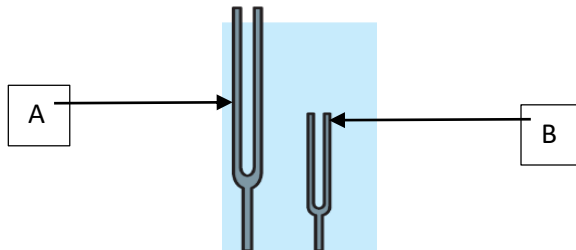

1. Identify the above instrument?

..... (1 Mark)

2. Which of the above instrument has the highest frequency?

..... (1 Mark)

3. Name the unit which used to measure the Frequency of vibrations?

..... (1 Mark)

4. Instrument "B" has mentioned as 512 Hz. What do you meant by it?

..... (1 Mark)

5. What do you mean by music and noise?

..... (1 Mark)

(Total – 11 Marks)