



PROVINCIAL DEPARTMENT OF EDUCATION NORTH WESTERN PROVINCE



THIRD TERM TEST - 2018
SCIENCE - I

Grade 10

One Hour

Name / Index No. :

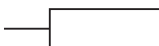
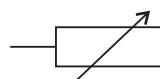
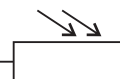
• Answer all the questions.

01. The deficiency disease of Vitamin B is,
(1) Night blindness (2) Tooth decay (3) Scurvy (4) Change in complexion
02. Which of the following organelle functioning as packaging and secretion,
(1) Golgi Complex (2) Endoplasmic reticulum
(3) Vacuole (4) Cell Plasma
03. Two metals that can be extracted by electrolysis are,
(1) Fe and Ag (2) Zn and Pb (3) Na and K (4) Pt and Au
04. Which of the following is a symbol of a permanent resistor,
(1)  (2)  (3)  (4) 
05. Which of the following word is most suitable to fill the space in given statement, "The process by which the energy and the materials are obtained for the maintenance of life is known as"
(1) Respiration (2) Growth (3) Nutrition (4) Excretion
06. Given below are three statements regarding to the chemical reactions,
A - During burning Mg in air it emitted bad odour gas.
B - A strip of Zn is added to a solution of CuSO₄ it can be observed reducing of colour.
C - While Heating KMnO₄ in a boiling tube inserted a glowing splint into it, then splint relights.
Select the correct answer,

	Statement A	Statement B	Statement C
(1)	Correct	Correct	Incorrect
(2)	Incorrect	Incorrect	Correct
(3)	Correct	Incorrect	Incorrect
(4)	Incorrect	Correct	Correct

07. An element can be used to prevent rusting of iron is,
(1) Mg (2) Sn (3) Pb (4) Cu
08. Given below are some elements in the periodic table. Out of it which element had highest first ionization energy?

H									
								Ne	
Na			Si						

09. Given below is a balance chemical reaction that take place in a blast furnance associated with reduction of hematite,



If the mass of Iron produced is 112kg. Calculate the mass of carbon dioxide released to the environment,

(Fe = 56, C = 12, O = 16)

- (1) 4.4 kg (2) 0.44 kg (3) 66 kg (4) 132 kg
10. Take four test tubes and add 10ml of dilute HCl to each tubes. Added equal pieces of cleaned Mg, Fe, Cu and Zn separately to the test tubes. What is the metal that release air bubbles faster ?
- (1) Mg (2) Fe (3) Zn (4) Cu

11. Given below are some functions of several cell organells,

A - Transfer inherited charactors B - Provide energy to the cell

C - Controls biological activities of cell D - Synthesis of protein

The function of nucleons is,

- (1) A and B (2) A and C (3) B and C (4) B and D

12. The correct statement about tissue culture is,

- (1) It can be done easily with out controlled environmental conditions.
 (2) Cannot be obtained large number of off springs at the same time is disadvantageous.
 (3) Can be obtained new, varities is an advantageous.
 (4) Can be produced offsprings which are identical to mother plant.

13. A garden pea plant with homozygous round seeds (RR) Crossed with homozygous wrinkled seeds (rr) The Phenotypes of first generation of above cross is,

- (1) All are round seed plants.
 (2) All the plants are homozygous.
 (3) The ratio between round seeds and wrinkled seeds is 3:1.
 (4) The ratio between homozygous and hetrozygous seeds are 2:1.

14. Number of N atoms present in 30g of Urea $\text{CO}(\text{NH}_2)_2$ is, (C = 12, O = 16, N = 14, H = 1)

- (1) 6.022×10^{23} (2) $2 \times 6.022 \times 10^{23}$
 (3) $3 \times 6.022 \times 10^{23}$ (4) $4 \times 6.022 \times 10^{23}$

15. An object starts its motion with velocity of 10 ms^{-1} and get the uniform deceleration during 5 seconds and becomes rest, Displacement of object during this time period is,

- (1) 2 m (2) 15 m (3) 25 m (4) 50 m

16. Given below are some chemical changes,

A - Ripening of mango fruit

B - Blasting of a craker

C - Ignition of petrol

D - Reaction of Mg with dil acid

E - Rustion of iron

Slow reactions from above are,

- (1) A and E (2) B and C (3) B and D (4) C and D

17. An object projected to upward with initial velocity of 40 ms^{-1} and it reaches to the maximum height. The relevant velocity time graph of above motion is,

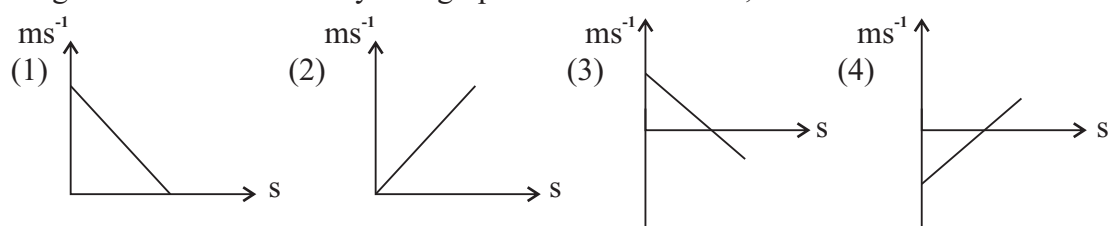

- Question No. 18 and 19 are based on following velocity time graph which shows the motion of an object with mass of 10kg.

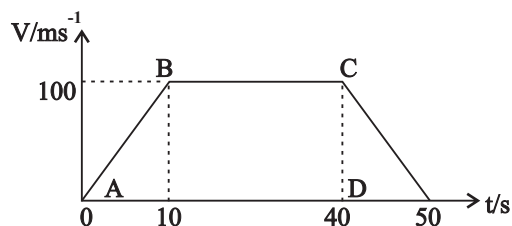

18. What is the resultant force act on an object during the motion from A to B.
- (1) 10 N (2) 100 N (3) 1000 N (4) 10 000 N
19. The acceleration of object from B to C is,
- (1) 0 ms^{-2} (2) 10 ms^{-2} (3) 20 ms^{-2} (4) 200 ms^{-2}

- Question number 20 and 21 are based on type of Carbohydrates given below,

A Maltose B Sucrose C Cellulose
 D Galactose E Glycogen

20. Examples of polysaccharides are,
- (1) A and B (2) B and D (3) C and E (4) D and E
21. The carbohydrates with fomula of $\text{C}_{12}\text{H}_{22}\text{O}_{11}$ are,
- (1) A and B (2) B and C (3) C and D (4) D and E
22. Which of the following is a feature of meiosis cell division,
- (1) Daughter cells are identical to the mother cell.
 (2) Do not occur variations.
 (3) Decreasing the number of Chromosomes during the cell division.
 (4) Takes place in one stage.
23. Which of the following is an adaptation of fruit and seeds to dispersed by animals,
- (1) Light weight (2) Having hooks and hair
 (3) Having thorns (4) Having fibrous pericarp

24. The method of vegetative propagation given in the diagram is,

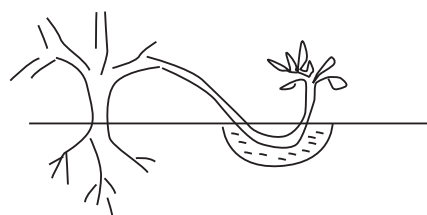

- (1) Ground layering (2) Arial layer
 (3) Twig grafting (4) Bud grafting

25. Given below is a method of collecting gas,

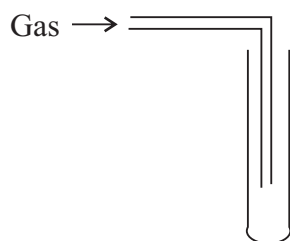

The relevant physical property considered in here and the name of that gas is,

- (1) The mass is less than that of atmosphere - H_2
 (2) Colourless - O_2
 (3) Density is grater than of atmospheric air - CO_2
 (4) Soluble in water - N_2

26. The melting point and boiling point of a compound is 801°C and 1413°C respectively. The correct statement about above compound is,

- (1) Consists of covalent bonds.
 (2) Donot conduct electricity through aqueous solution.
 (3) It is in liquid state at room temperature.
 (4) Consists of ionic bonds.

27. Select the unbalanced equation from given choices,

- (1) $\text{CO}_2 + \text{C} \rightarrow 2\text{CO}$ (2) $\text{H}_2 + \text{Cl}_2 \rightarrow 2\text{HCl}$
 (3) $\text{Mg} + 2\text{HCl} \rightarrow \text{MgCl}_2 + \text{H}_2$ (4) $\text{Mg} + \text{O}_2 \rightarrow \text{MgO}$

28. Diagram given below shows a wooden block which hang to a Newton balance, Then it immersed in four liquids separately. In which liquid shows the lowest reading of the Newton balance,

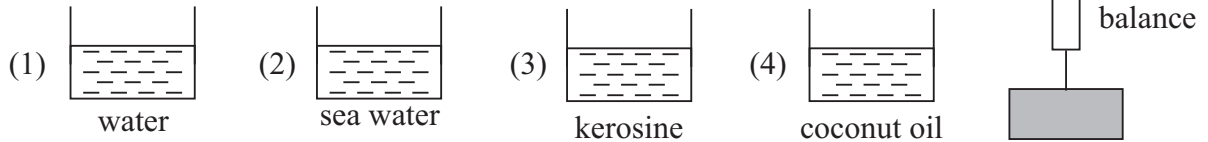

29. Diagram shows a hydrometre immersed in water.

Some detections can be gain by this activity are given below,

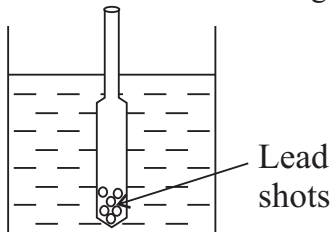

- A - The upthrust which acting by the liquid is equal to the weight of the hydrometer.
 B - The upthrust which acting on hydrometer is equal to the displaced weight of liquid.
 C - The lead shots are accommodated to kept hydrometre vertically in liquid.

The correct statements are,

- (1) A (2) A and C (3) B and C (4) A, B and C
 30. Find the work done by an object with mass of 500g when lifting upwards by 2m,
 (1) 1 J (2) 2 J (3) 10 J (4) 1000 J
 31. The circuit diagram which can be used to measure voltage difference of a bulb is,

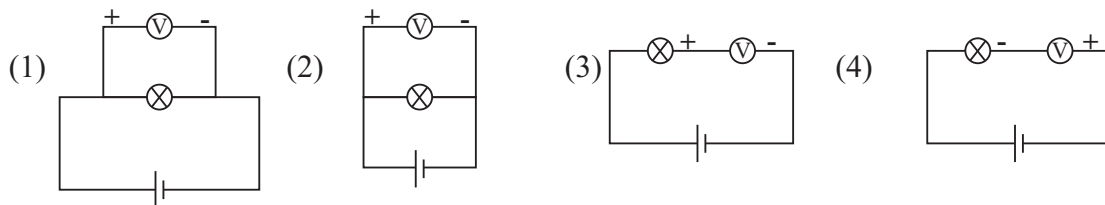

32. What is the value of permanent resistor shown in the diagram,

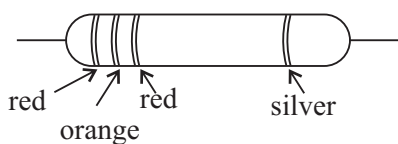

- (Red = 2, Orange = 3, Silver = 10%)
 (1) 232 (2) 2300
 (3) 23 K (4) 2300 K

33. Given below are some characteristics of organisms,

- a made up with chitinous cell wall b ability to photosynthesis
 c Decomposition of organic matter d belongs to domain Eukarya

The characteristics belongs to kingdom fungi is,

- (1) a, b and c (2) a, c and d (3) a, b and d (4) b, c and d

34. Find the velocity of a bird with mass of 200g to acquire equal momentum to the bullet with mass of 10g moved with velocity of 500 ms^{-1} .

- (1) 5 ms^{-1} (2) 10 ms^{-1} (3) 15 ms^{-1} (4) 25 ms^{-1}

35. Given below are some instances of frictional force act to an object

Instance	Type of frictional force
A In stationary of object	D Dynamic frictional force
B Just begins to move the object	E Static frictional force
C Have relative motion to object	F Limiting frictional force

A correct relationship given below is,

- (1) A and E (2) B and D (3) B and E (4) C and F

36. Diagram shows an object 'X' placed on a smooth horizontal plane. A and B are two forces act on object X.

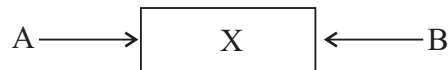

Object moves towards the B with resultant force of 5N. Values of A and B are respectively,

- (1) 15 N and 20 N (2) 25 N and 5 N (3) 30 N and 25 N (4) 50 N and 30 N

37. Select the circuit which glow bulb a brightly, Consider resistance of each resistor is 2Ω and bulbs have equal specification.

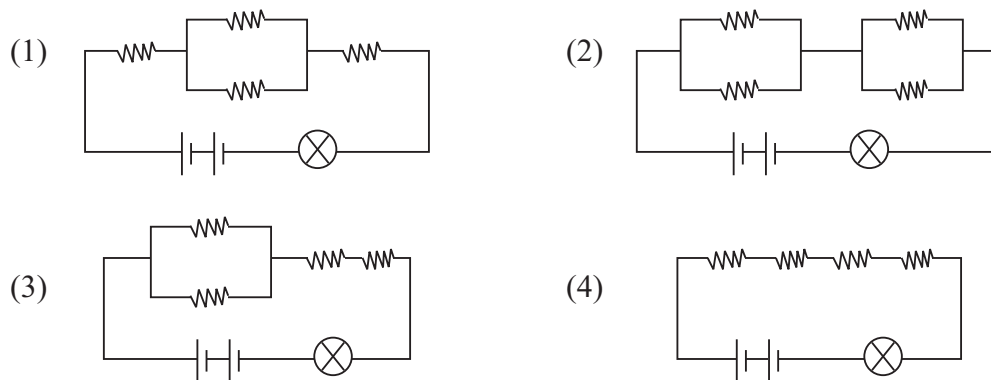

38. A, B, C, D and E are five elements. The atomic numbers are 5, 9, 11, 19 and 10 in respectively. The elements belong to the I group of the periodic table are, (Given symbols are not standard symbols)

- (1) A and B (2) B and C (3) C and D (4) D and E

39. Given below are some diseases commonly seen in present. Select the infections disease among them,

- (1) Rabies (2) Haemophilia
(3) Thalassemia (4) Red green colour blindness

40. Deforestation is a human activity that most affected to the environment. The problem which arised as long term effect of it is,

- (1) Soil erosion (2) lost habitats of organisms
(3) Reducing of depth of rivers (4) Unfavorable changes of climate



PROVINCIAL DEPARTMENT OF EDUCATION NORTH WESTERN PROVINCE

THIRD TERM TEST - 2018

Grade 10

SCIENCE - II

Three Hours

Name / Index No. :

Common instructions :

- Use clean hand writing
- Answer four question in part A in given space.
- Answer to only three questions in B part out of 5 question.

Part A - Structural Essay

01. A) Following is the way of storing labouratory specimans and chemicals in a rack of a certain school labouratory.

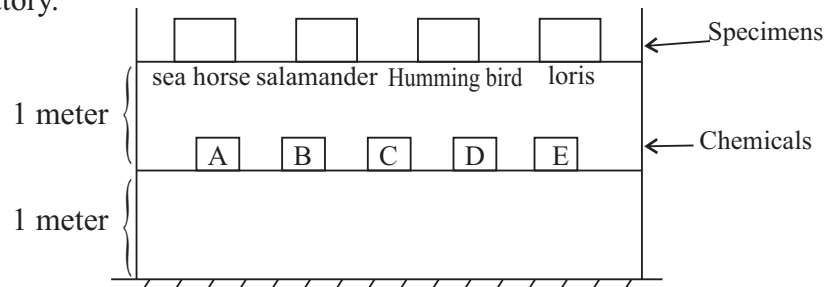

(i) Mass of A chemical and mass of sea horse speciman is m and $2m$ in respectively. If gravitational acceleration (g) is 10ms^{-2} , write an expression for the weight (W) of sea horse speciman by using W , m and g . (01m.)

.....

(ii) When storing speciman with sea horse and chemical A in rack, which one contains more potential energy. Explain the reason in briefly. (02m.)

.....

.....

(iii) Due to stricked hand to the container with sea horse, it fallen down in freely. Draw the relevant velocity time graph to that motion. (02m.)

B) In 1 column of following table given characteristics of organisms in above specimens. If it present in animals mentioned in columns 2, 3, 4, 5 put (✓) mark.

(i)	1	2	3	4	5
	Characteristics	sea horse	salamander	Humming bird	lemur
	Present gills				
	Three chambered heart				
	Body covered with hairs				
	Warm blooded (Homoiothermic)				
	Fore limbs are converted into wings				

(03m.)

(ii) Select and write the name of animal which needs both land and water to complete their life cycle. (01m.)

.....

(iii) Define what did meant by "homoiothermic" (01m.)

.....

C) Following chemicals are contain in bottles given above figure.



Description of each chemicals are illustrated in following table.

Chemical	Description
A	When adding Mg piece to solution release H_2 .
B	Anhydrous state is in white and hydrous state is in blue
C	Used as a food flavour.
D	Absorb water vapour in atmosphere
E	Purple coloured solution
F	Used to cleanse a wound

(i) Identify chemical from A to F. (03m.)

A B C

D E F

(ii) Mention the chemicals exists as an aqueous solution under room temperature.

..... (01m.)

(iii) State the chemical can be used to produce O_2 gas. (01m.)

.....

(Total marks 15)

02. A) Production of plants vegetatively by man is known as artificial vegetative propagation.

(i) Write two methods of artificial vegetative propagation. (02m.)

i) ii)

(ii) Mention an advantage and a disadvantage of artificial vegetative propagation. (02m.)

.....

(iii) What is the method of producing large number of plants by cultivating a vegetative tissue under controlled condition? (01m.)

.....

B) Following figure shows the changes of hormones during menstrual cycle.

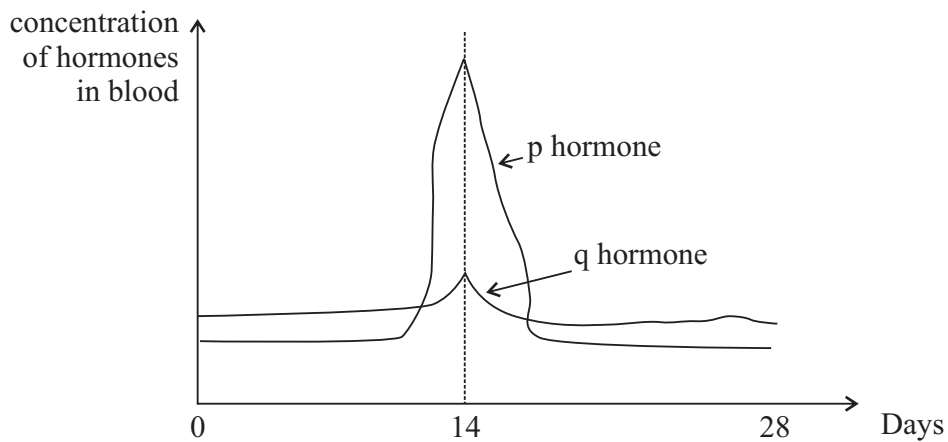

(i) Name p and q hormones. (02m.)

p q

(ii) What is the change that takes place on 14th day in the menstrual cycle? (01m.)

.....

(iii) Where did the fertilization takes place in female reproductive system? (01m.)

.....

(iv) What is the structure important to exchange materials between mother and foetus? (01m.)

.....

C) There are common inherited characteristics for a species. But the organisms belong to a single species are not similar.

(i) What is an inherited character? (01m.)

.....

(ii) Write two common inherited characteristics in human. (02m.)

1.

2.

- (iii) Several genetic disorders occur due to sex linked recessive gene. Write two such disorders. (02m.)

.....

(Total marks 15)

03. A) Atomic number and mass number of an oxygen atom is 8 and 16 in respectively.

- (i) What is define as atomic number? (02m.)

.....

- (ii) Write the electronic configuration of an oxygen atom. (01m.)

.....

- (iii) Mention the element which present same electronic configuration to O^{2-} ion. (02m.)

.....

- (iv) Write two physical properties of O_2 gas. (01m.)

.....

.....

Given below is the set up used to produce oxygen gas.

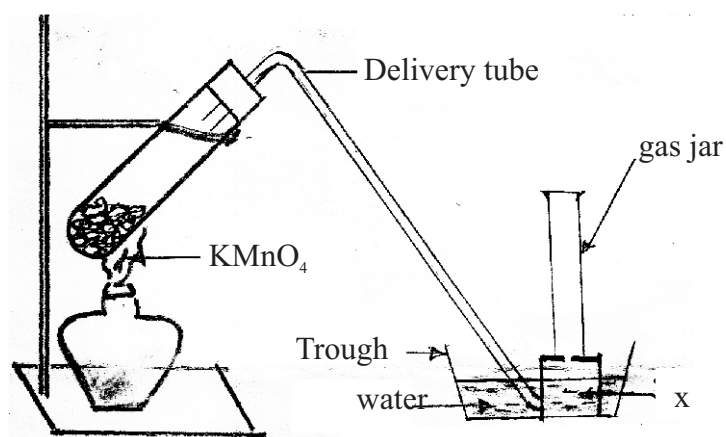

- (v) Write an error in preparation of above set up. (01m.)

.....

- (vi) Name the instrument given as *x*. (01m.)

.....

- (vii) Mention the identified way of gas collected in gas jar.

.....

..... (02m.)

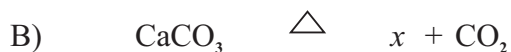

Given above is a chemical decomposition reaction.

- (i) Write the chemical formulae of compound given as *x*. (01m.)

.....

- (ii) Calculate the relative molecular mass of CaCO_3 . (Ca - 40, C - 12, O -16) (02m.)

.....

.....

.....

- (iii) What is the mass of 2 mol of CaCO_3 ? (02m.)

.....

.....

.....

(Total marks 15)

04. A) A model to demonstrate hydraulic press which used to hoist vehicles is given in below. *x* and *y* are the devices used to avoid returning of oil. At necessary instances those can be off.

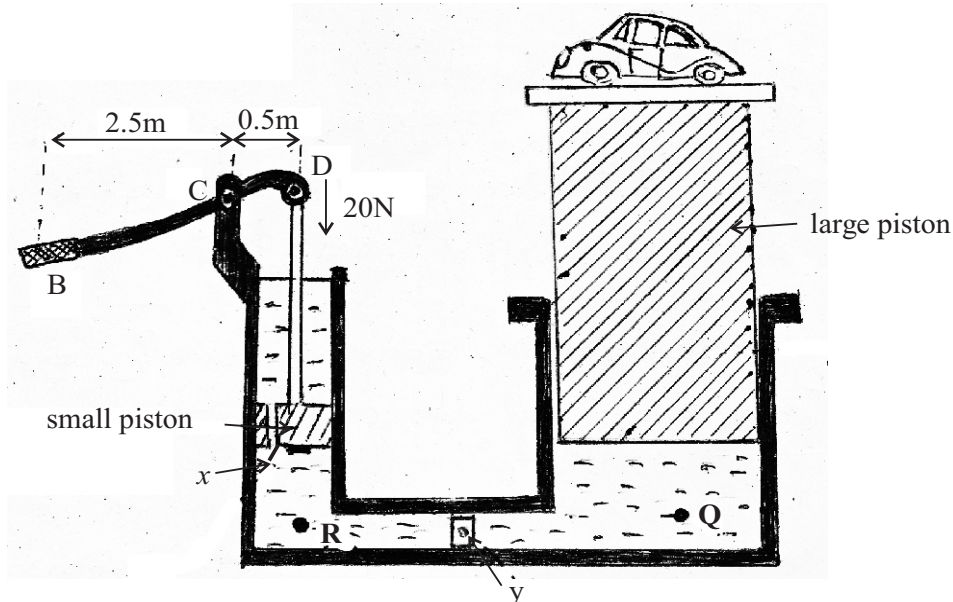

- (i) During *y* device offed, what can you say about the pressure of R and Q points? (01m.)

.....

- (ii) What will happen to the pressure of R, when moving handle B to upward? (01m.)

.....

(iii) If the area of small piston is $(A) = 0.1\text{m}^2$ and a force of $(F) 20\text{N}$ act on it. Build up an expression for the pressure (P) act on oil using F and A . (01m.)

.....

(iv) Calculate the pressure given by small piston. (02m.)

.....

.....

(v) If area of large piston is 2m^2 , calculate the force exerted on it by oil. (02m.)

.....

.....

.....

(vi) To exerted 20 N force by the small piston calculate the applied force to the end of handle (B) . Neglect the frictional force. (02m.)

.....

.....

(vii) What can you say about the distance moved by the small piston to downward and large piston to upward, when lifted the handle once? (01m.)

.....

.....

(viii) What is the physical property of liquid applied in above model?

..... (01m.)

(ix) Write two places where energy can waste due to frictional force.

i) ii) (02m.)

(x) Write another two instances where pressure transmitted through liquids. (02m.)

.....

.....

(Total marks 15)

BIOLOGY

05. A) Carbohydrates consist only C, H and O.
- (i) Write the ratio between H and O in Carbohydrates. (01m.)
 - (ii) Write 02 elements in nucleic acids instead of above 03 elements. (01m.)
 - (iii) DNA is a type of nucleic acid. Write the name of another type of nucleic acid. (01m.)
 - (iv) Write 02 names of products formed due to changing genotype by removing or adding extra DNA fragments into genes. (02m.)
 - (v) Write a deficiency symptom from following elements in animal body.
 - (a) Iodine
 - (b) Calcium
 (02m.)

Following is a diagram of a typical cell.

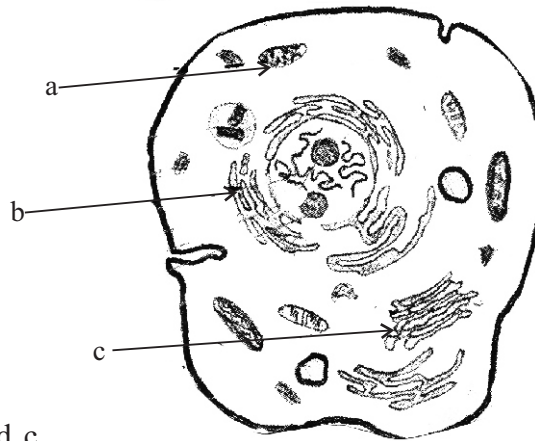

- (vi) Name a, b and c. (01m.)
 - (vii) Does this diagram is a plant cell or an animal cell ? (01m.)
 - (viii) Write 02 factors help to get above answer. (01m.)
- B) (i) Write 05 organizational levels that can be identified in a living being respectively. (01m.)
- (ii) What is the main factor used to divided animals in kingdom animalia. (01m.)
 - (iii) Write relevent phyla for following animals. (02m.)
 - (a) Earth worm
 - (b) Startfish
 - (c) sea anemone
 - (d) Cattle fish
 - (iv) Kingdom plantae is divided into 02 groups based of produce flowers or donot produce flowers. Write 2 non flowering seedless plants. (01m.)
 - (v) Mention a difference of flowers between monocotyledonae plant and dicotyledonae plant. (01m.)
 - (vi) Write a way of differentiate monocotyledonae plant and dicotyledonae plant when germinating seeds. (01m.)
 - (vii) Write 02 factors needed for germinating seeds in above dicotyledonae plant. (02m.)
 - (viii) What is the method used to remove dormancy of orange seeds? (01m.)

(Total marks 15)

06. A)

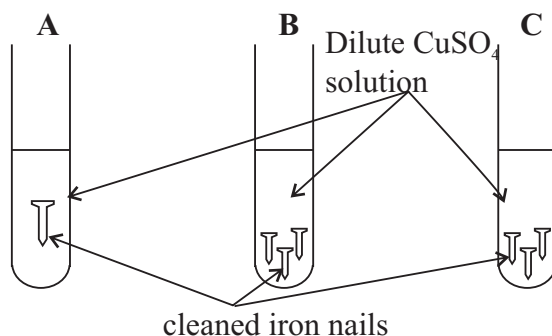

Above diagram shows 03 set ups prepared for testing factors affected for rate of reaction. Informations of each test tube are given below.

Tube A	Tube B	Tube C
temperature is 30 C, Dilute solution, added 15g of a nail.	temperature is 40 C, concentrated solution 3 nails, of each 5g are added.	temperature is 40 C, concentrated solution. 3 nails, of each 5g are added.

- (i) Write 02 factors affected for rate of reaction which are expected to test in above experiment. (01m.)
- (ii) Mention 02 observation expected by above reaction. (01m.)
- (iii) After 10 minutes, what is the test tube contains, highest amount of precipitation ? (01m.)
- (iv) Explain the reason for above answer. (02m.)
- (v) Mass of the precipitate formed in C tube is 5g within 10 minutes. Calculate the rate of reaction. (02m.)
- (vi) Write the balanced chemical equation for above reaction. (02m.)

B) Given belows are 02 isotopes in same element.



- (i) Define 'Isotopes'. (02m.)
- (ii) What is the sub atomic particle changed numerically in atomes of isotopes? (01m.)
- (iii) Draw a chlorine isotope using standard symbols. (02m.)
- (iv) Write the valency of above isotope. (01m.)

C) Above diagram shows a standard method of writing a chemical compound.

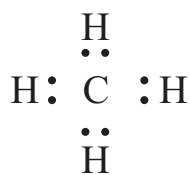

- (i) What is the name of the standard method mentioned above. (01m.)
- (ii) How many electrons in valence shell in C atom, before it make the bonds? (01m.)
- (iii) Draw the lewis structure of above compound. (02m.)
- (iv) What is the type of bond in between C and H atoms here? (01m.)

(Total marks 20)

07.A) 60kg of bucket filled with cement is raised vertically upward to scaffold (palanchiya) within 30 second by a machine. 1.75kg of electrical energy is spent by the machine for the work.

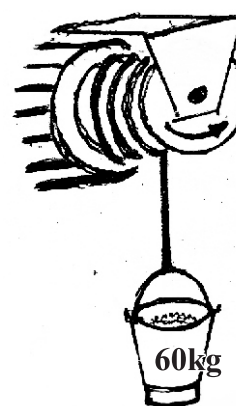

- (i) Calculate the minimum force applied by the machine to raised cement bucket. (02m.)
- (ii) If the work done by machine to raised cement bucket is 1200J. Find the height of scaffold (palanchiya) (02m.)
- (iii) Find the power of the machine. (01m.)
- (iv) Write the energy transformation when working the machine. (01m.)
- (v) Find the potential energy of cement bucket when it is on the scaffold. (02m.)

(vi) Calculate the energy wasting in above energy transformation. (02m.)

B) Following apparatus prepared to find the factors affected for resistance in a conductor. Observations are taken by connecting x to B, D, and F.

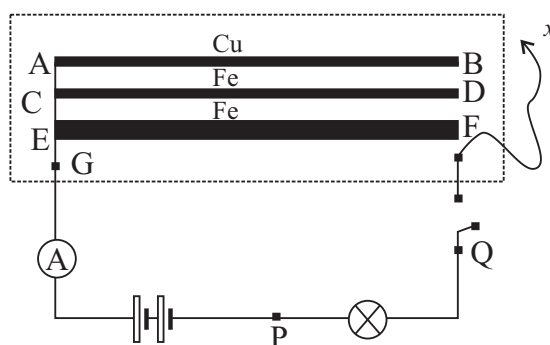

- (i) What are the instruments used to get observation in above apparatus? (02m.)
- (ii) What are the 2 factors prevailed constant in AB and CD metal wires. (02m.)
- (iii) (a) Out of B and D, which one gives highest reading in ammeter? (01m.)
- (b) Explain the reason for your answer. (02m.)
- (iv) Name the instrument used for protec the ammeter. (01m.)
- (v) What is the difference takes place of reading of ammeter when P and Q is connected using an extra conductor? (01m.)
- (vi) What is the factor affected for resistance can be identify by connecting 'x' into D and F. (01m.)

(Total marks 20)

08. A) Following set up is prepared for observing growth of a plant.

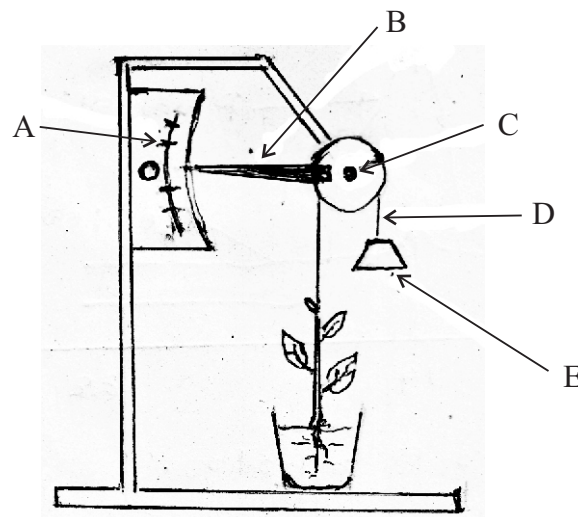

- (i) Name the above set up? (01m.)
- (ii) Name A, B, C and D. (02m.)
- (iii) What is the change in B when plant is growing? (01m.)
- (iv) Mention a change of the set up that has to do to get accurate growth of the plant. (01m.)
- (v) Define a Dioecious plant with examples. (02m.)
- (vi) Define pollination of a plant. (02m.)
- (vii) Write an adaptation of flowers to avoid self-pollination. (01m.)

B) Following diagram shows behaviour of positively charged rigid foam ball which close to charged insulating rod.

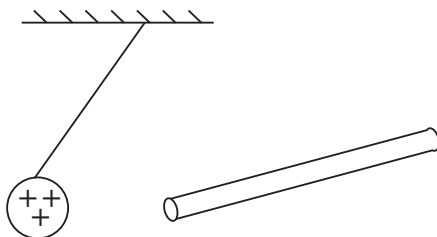

- (i) What is the meaning of 'charging'? (01m.)
- (ii) What is the charge in end of insulating rod? explain the reason of your answer. (02m.)

C) Given below is a simple electric circuit.

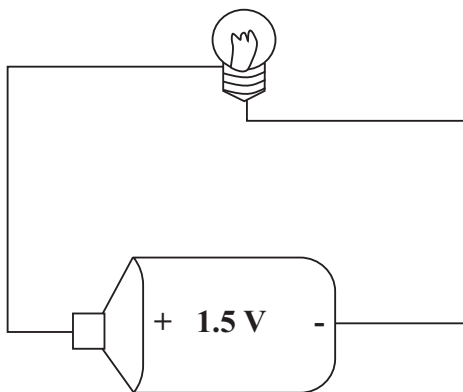

- (i) Draw the above circuit using standard symbols. (01m.)
- (ii) Draw the way of flowing electric current in circuit using an arrow head? (01m.)
- (iii) Electric current flows through the conductors but not in insulators. Explain the reason. (02m.)
- (iv) What is the electromotive force in electric cell? (01m.)
- (v) The electric current flows through the filament bulb is 0.3A. Find the resistance of the filament bulb. (02m.)

(Total marks 20)

09. A) Here are some informations about few oxides of elements,

elements in 3 rd period	Na	Mg	Al	Si	P	S	Cl	Ar
formulae of oxide	Na ₂ O	MgO	-	SiO ₂	P ₂ O ₅	SO ₃	Cl ₂ O ₇	-

- (i) Write the formulae of Aluminium oxide. (01m.)
- (ii) Ar does not form oxides. Explain the reason. (02m.)
- (iii) Among these oxides write a strong basic oxide and a strong acidic oxide. (02m.)
- (iv) What is the colour of crystalline of S? (01m.)
- (v) Write an observation of sulphur during its burning in air. (01m.)
- (vi) Mention 02 physical properties of Na metal. (02m.)
- (vii) Write an instance of using Cl in daily life. (01m.)

B) Following diagram shows a set up used in experiments related to atmospheric pressure.
Density of mercury is 13600 kgm⁻³.

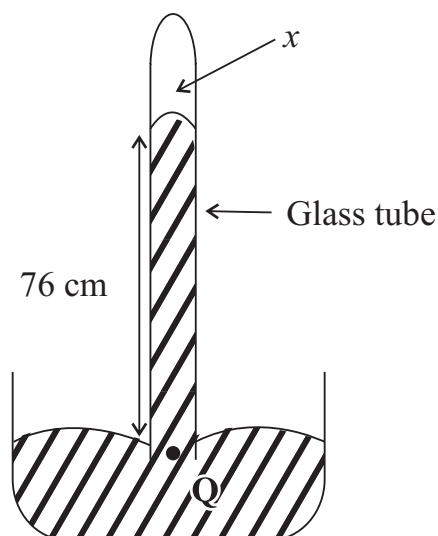

- (i) Name 'X'. (01m.)
- (ii) Write 02 factors affected for the pressure of Q. (02m.)
- (iii) Find the pressure at Q given by mercury column. (02m.)
- (iv) What is the difference in height of mercury column when it is brought from sea-level to up in vertically? (01m.)
- (v) Explain the reason for your answer. (02m.)
- (vi) Write 02 instruments which use atmospheric pressure. (02m.)

Answer Paper - Part I

01. (4) 02. (1) 03. (3) 04. (1) 05. (1) 06. (4) 07. (1) 08. (2) 09. (4) 10. (1)
 11. (2) 12. (4) 13. (1) 14. (1) 15. (3) 16. (1) 17. (1) 18. (2) 19. (1) 20. (3)
 21. (1) 22. (3) 23. (2) 24. (1) 25. (3) 26. (4) 27. (4) 28. (2) 29. (4) 30. (3)
 31. (1) 32. (2) 33. (2) 34. (4) 35. (1) 36. (3) 37. (2) 38. (3) 39. (1) 40. (4)

(40 x 2 = 80m.)

PART A - Structural Essay

01. A (i) $W = 2m \times g$ (01m.)
 (ii) sea horse specimen (01m.) for giving reasons (01m.)
 (iii) for naming axes (01m.)
 for shape of graph (01m.)

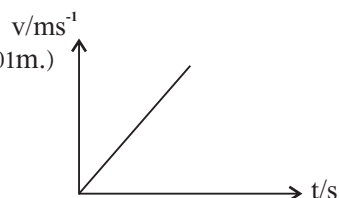

B (i)

	1	2	3	4	5
characteristics		sea horse	salamander	humming bird	lemur
a		✓			
b			✓		
c					✓
d				✓	✓
e				✓	

(03m.)

- (ii) Salamander (01m.)
 (iii) Body temperature is not changed according to environmental temperature... (01m.)
- C (i) $A = H_2SO_4$ $B = CuSO_4$ $C = NaCl$ $D = CaCl_2$ $E = KMnO_4$ $F = H_2O_2$ (03m.)
 (ii) H_2SO and H_2O_2 (01m.) (iii) $KMnO_4$ and H_2O_2 (01m.)
02. A (i) Tissue culture, layering, grafting or rooting of stem cuttings (02m.)
 (ii) for an advantage and a disadvantage (02m.) (iii) Tissue culture (01m.)
- B (i) $p = LH$ hormone $q = FSH$ hormone (02m.)
 (ii) Ovulation (01m.) (iii) In fallopian tube (01m.)
 (iv) Umbilical cord (01m.)
- C (i) The features transmitted from generation to generation. (01m.)
 (ii) Skin colour, ability to fold the tongue, curly or straight hair, etc..... (02m.)
 (iii) Colour blindness and hemophilia (02m.)
03. A (i) The number of protons in a nucleus of an atom of the element. (02m.)
 (ii) O 2.6 (01m.) (iii) Ne (02m.)
 (iv) For 02 correct properties (02m.)
 (v) Keeping of water level lower than the upper boundry of beehive shelf. (01m.)
 (vi) Beehive shelf (01m.)
 (vii) for the practical of identify O_2 gas(02m.)
- B (i) CaO (01m.) (ii) For correct calculation (02m.)
 (iii) For correct calculation (02m.)

04. A (i) Equal (01m.) (ii) Increased (01m.)
- (iii) $P = \frac{F}{A}$ (01m.) (iv) $\frac{20}{0.1} = 200 \text{ Nm}^{-2}$ (02m.)
- (v) $2 \times 200 \text{ Nm}^{-2} = 400 \text{ N}$ (02m.)
- (vi) $0.5 \times 20 = 2.5 \times \text{Force}$ or $2.5 \times \text{Force} = 20 \times 0.5$
- $$\begin{aligned} \text{Force} &= \frac{20 \times 0.5}{2.5} \\ &= \frac{20 \times 5}{25} \\ &= \frac{100}{25} \\ &= 4 \text{ N} \end{aligned}$$
- (02m.)
- (vii) Large piston moved less distance to upward than the small piston. moved to downward. (01m.)
- (viii) Due to not compressed by forces. (01m.)
- (ix) At C, D or the surface between pistons and cylinder. (02m.)
- (x) A hoist, hydraulic jack, vehicle break system etc..., (02m.)
05. A (i) H : O = 2:1 (01m.) (ii) N, S, C (01m.)
- (iii) RNA (01m.)
- (iv) Golden rice enriched with vitamin A, High productive cattle, milk with high nutritious value, weedicide resistance crops by inserting a gene obtained from a bacterium etc., (02m.)
- (v) (a) Limits body height, Affects development of intelligence, lethargic attitude towards studies (01m.)
- (b) Rickets, weakening of teeth and bones, Growth disorders etc., (01m.)
- (vi) (a) Mitochondrion (b) Endo-Plasmic reticulum (c) Golgi bodies (01m.)
- (vii) Animal cell (01m.)
- (viii) Absent of cell wall, absent of chloroplast, absent of large vacuoles (01m.)
- B (i) cell tissue organ system organism (01m.)
- (ii) Based on presence of absent of backbone. (01m.)
- (iii) (a) Annelida (b) Echinodermata (c) Cnidaria (d) Mollusca (02m.)
- (iv) Such as Pogonatum, Marchantia, Sellaginella, Salvinia.... etc., (01m.)
- (v) In monocot plants contain trimerous flowers while dicot plants contain tetra or pentamerous flowers. (01m.)
- (vi) During germination monocot seeds present a seed leaf and dicot seeds present two seed leaves. (01m.)
- (vii) Such as air, (O₂), Water temperature, viability of seeds.... for 02 answers. (02m.)
- (viii) Growth by removing seed coat (01m.)

06. A (i) Temperature, Concentration of reactants, Surface area of reactants (02 factors from given) (01m.)
- (ii) Decreases the colour of solution forms a brownish colour precipitation (01m.)
- (iii) C tube (01m.)
- (iv) Due to supply more temperature, more concentration and more surface area of reactants in C tube. (02m.)
- (v) Rate of reaction = $\frac{\text{Amount of produces formed}}{\text{Time taken}}$
- $$= \frac{5\text{g}}{10 \text{ min}}$$
- $$= 0.5 \text{ gmin}^{-1} \quad (02\text{m.})$$
- (vi) $\text{CuSO}_4 + \text{Fe} \rightarrow \text{FeSO}_4 + \text{Ca}$ (02m.)
- B (i) The atoms with different mass numbers in the same element. (02m.)
- (ii) Neutrons (01m.) (iii) ${}^{35}_{17}\text{Cl}$ ${}^{37}_{17}\text{Cl}$ for one (02m.)
- (iv) Ones (01m.)
- C (i) Lewis dot diagram (01m.)
- (ii) Four (01m.) (iii) $\begin{array}{c} \text{H} \\ | \\ \text{H}-\text{C}-\text{H} \\ | \\ \text{H} \end{array}$ (02m.)
- (iv) Covalent bonds (01m.)
07. A (i) $60 \times 10 = 600 \text{ N}$ (02m.)
- (ii) $600 \times x = 1200 \text{ J}$ $x = \frac{1200}{600} = 2 \text{ m}$ (02m.)
- (iii) $\frac{1200}{3} = 40 \text{ Jms}^{-1}$ (01m.)
- (iv) Electric energy Kinetic energy (01m.)
- (v) $1750 \text{ J} - 1200 \text{ J} = 550 \text{ J}$ (02m.)
- (vi) $\text{PE} = \text{Mgh}$ $60 \times 10 \times 2$ 1200J (02m.)
- B (i) Ametre and bulb (02m.)
- (ii) Length of the conductor and cross sectional area (02m.)
- (iii) (a) Place at B (01m.)
- (b) Conductivity of copper is greater than iron (02m.)
- (iv) Rheostat (01m.) (v) Increased (01m.)
- (vi) Thickness / cross sectional area (01m.)
08. A (i) Auxonometer (01m.)
- (ii) A = Scale B = Indicator C = Pulley D = Pulley (02m.)
- (iii) Indicator moved to upward or suitable answer. (01m.)

- (iv) Such produce the length of indicator, reduce the frictional force of the pulley, risen the frictional force of the string etc., Fr suitable one answer. (01m.)
- (v) Staminate flowers and pistilate flowers are born separately on two plants are called as dioecious plants. (02m.)
- (vi) The depositing of matured pollen on the stigma of the flower of the same species.(02m.)
- (vii) Having unisexual flowers, self-sterility, Hercogamy, Dichogamy, having extrose stamens (01m.)

- B (i) Due to rubbing insulating objects can charged to attract materials. (01m.)
- (ii) Positively charged
Because (+) vely charge objects are repel from positive charges (02m.)

- C (i)  (01m.)

- (ii) Illustrating the direction of current in above diagram. (01m.)

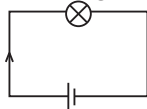

- (iii) Free electrons present in conductors / Free electrons are not present in insulators. (02m.)
- (iv) Voltage difference between terminals when there is no external circuit or any other correct explanation. (01m.)
- (v) $R = \frac{V}{I}$ $R = \frac{1.5 V}{0.3 A} = 5 \Omega$ (02m.)

09. A (i) Al_2O_3 (01m.)
- (ii) Such, due to a noble gas, or any acceptable answer, (due to not contain stable electronic configuration.) (02m.)
- (iii) Strongly basic Na_2O Very weakly acidic SiO_2 / P_2O_5 (02m.)
- (iv) Yellowish colour (01m.)
- (v) Burning with blue flame / form sulphur dioxide malodour as.... for 1 observation - (01m.)
- (vi) A soft metal / density is less than water / Present off silvery lustre for acceptable answer. (02m.)
- (vii) for correct usage. (01m.)

- B (i) Vaccum (01m.)
- (ii) Density of liquid Height of liquid column (02m.)
- (iii) $P = h g$
 $P = \frac{76 \text{ cm Hg}}{100} \times 13600 \text{ kgm}^{-3} \times 10 \text{ms}^{-2}$ (02m.)
 $= 103360 \text{ Pa}$

- (iv) Gradually decreased (01m.) (v) for correct explanation (02m.)
- (vi) for two correct answers (02m.)