

12. Several strategies used to increase friction are given below

- a) Making grooves at the sole of shoes
- b) Grooves are etched on the surface of tyres
- c) Making the rubber break pads rough.

Out of the above, the strategies use to make the motion easy are,

- (i) a and b only
- (ii) b and c only
- (iii) c and c only
- (iv) a,b, c all

13. The factor of water which is not important to maintain the life is,

- (I) Having less melting point
- (ii) Having high specific heat capacity.
- (iii) Being a good solvent
- (iv) Being a medium of transport.

14. Answer which shows the correct isotope of carbon is,

- (I) ${}^6_{12}\text{C}$ ${}^6_{13}\text{C}$
- (ii) ${}^{12}_6\text{C}$ ${}^{13}_6\text{C}$
- (iii) ${}^{12}_6\text{C}$ ${}^{12}_7\text{C}$
- (iv) ${}^{12}_6\text{C}$ ${}^7_{12}\text{C}$

15. A student started the motion at A, traveled half of the circumference of a circle with radius 14m and stopped at B. Select the answer which shows distance and displacement.

- (I) 14m and 14m
- (ii) 44m and 28m
- (iii) 44 and 44m
- (iv) 88m and 44m

16. Given below are some answers received as the factors needed for photosynthesis. The correct answer is,

- (I) Carbon dioxide, Oxygen, Sun light, Water
- (ii) Chloroplast, Carbon dioxide, Oxygen, Water
- (iii) Water, Sun light, Glucose, Chloroplast
- (iv) Carbon dioxide, Sun light, Water, Chloroplast.

17. Select the double displacement reaction.

- (I) $\text{CaCl}_2 + \text{Na}_2\text{CO}_3 \rightarrow \text{CaCO}_3 + 2\text{NaCl}$
- (ii) $\text{Mg} + \text{H}_2\text{O} \rightarrow \text{MgO} + \text{H}_2$
- (iii) $\text{CuSO}_4 + \text{Zn} \rightarrow \text{ZnSO}_4 + \text{Cu}$
- (iv) $\text{CaO} + \text{H}_2\text{O} \rightarrow \text{Ca(OH)}_2$

18. Several statements regarding an object put into a liquid are given below

- (a) Decreasing the density of the object than density of liquid
- (b) Increasing the weight of the object than the upthrust
- (c) Equaling the weight of the object to upthrust.

Out of the above statements, which are **always** correct about floating object

- (I) a and b only
- (ii) b and c only
- (iii) a and c only
- (iv) a,b, c all

19. The answer which shows the gas X and how it is identified is,

- (I) Carbon dioxide/ glowing splinter burns brightly
- (ii) Carbon dioxide/ glowing splinter extinguishes
- (iii) Oxygen/ glowing splinter extinguishes
- (iv) Oxygen/ glowing splinter burns brightly

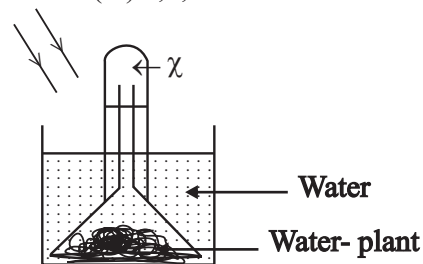

20. What is the element which forms an ionic compound by combining with chlorine with a +2 charge →

- (I) Sodium
- (ii) Sulphur
- (iii) Aluminum
- (iv) Magnesium

21. How much is the gravitational potential energy containing in an object of mass 50kg moving to a height of 40 cm from the ground level—($g = 10 \text{ ms}^{-2}$)

- (I) $\frac{50 \times 10 \text{ J}}{40}$
- (ii) $\frac{50 \times 40 \text{ J}}{10}$
- (iii) $50 \times 10 \times 40 \text{ J}$
- (iv) $\frac{40 \times 10 \text{ J}}{50}$

22. when a specimen of blood was observed under the high power of light microscope, several components were observed. A and B are,

- (I) Red Blood cells and platelet.
- (ii) Monocytes and Red Blood cells
- (iii) Eosinophil and Monocytes
- (iv) Red Blood cells and Platelet.

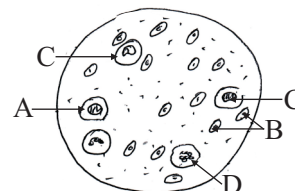

23. Which diagram illustrates the Lewis structure of hydrogen molecule →

- (i) $\text{H} \cdot \cdot \text{H}$
- (ii) $\text{H} - \text{H}$
- (iii) $\text{H} \times \text{H}$
- (iv) $\text{H} : \text{H}$

24. A hydrometer was put in to a liquid and measured the density of a liquid The correct observation and reason are,

Observation	Reason
(i) Hydrometer immersing more	(I) Density of the liquid is less and volume of water displaced is less.
(ii) Hydrometer immersing less	(ii) Density of the liquid is high and volume of water displaced is less.
(iii) Hydrometer immersing more	(iii) Density of the liquid is high and amount of water displaced is high.
(iv) Hydrometer immersing less	(iv) Density of the liquid is less and amount of water displaced is high.

25. Select the correct answer which gives the scientific name for the Jungle fowl

- (I) GALLUS LAFAYETII (ii) GALLUS *Lafayetii*
 (iii) *Gallus lafayetii* (iv) *gallus Lafayetii*

26. 3 moles of A and 12 moles of B are contained in a mixture of A and B. Mole fraction of B is,

- (I) 0.8 (ii) 0.6 (iii) 0.2 (iv) 0.12

27. The equation which can be used to find the resistance according to the ohm's law

- (I) $I = \frac{R}{V}$ (ii) $I = VR$ (iii) $V = \frac{I}{R}$ (iv) $V = IR$

28. Consider the following statements

- (a) Only Parenchyma and collenchyma are simple permanent tissues.
 (b) Phloem tissue is a simple permanent tissue, but xylem tissue is not a simple permanent tissue.
 (c) Panenchyma tissue is a simple permanent tissue

The incorrect statements are,

- (I) a only (ii) b only (iii) a and b only (iv) b and c only

29. Which statement is correct about the factors affecting solubility

- (i) Nature of the solute and nature of the solvent are affected only
 (ii) Nature of the solute, nature of the solvent and temperature are affected only.
 (iii) No effect of nature of solute and solvent.
 (iv) Nature of the solvent and temperature are only affected factors.

30. The necessity that should be to balance an object under 03 forces which are not parallel

- (I) Resultant of two forces should be equal to the magnitude of other force.
 (ii) The direction of the resultant of two forces should be equal or parallel to the direction of other force.
 (iii) The addition of 3 forces is equal to the resultant of two force.
 (iv) Two forces are single pointed and other force exists in an other point.

31. Not d disease associated with kidney.

- (I) Atherosclerosis (ii) Nephritis
 (iii) Stones in the kidney (iv) Failure of the kidney

32. Number of moles of which substance is similar to the number of moles of 11 g of carbon dioxide ,
 (C -12, H- 1, O-16, Na—23, Cl-35.5, N-14)

- (I) 45g of glucose (ii) 29.25g sodium chloride (iii) 13.5g of water (iv) 60g of urea

33. select the answer which shows the external appearance of light sensitive resistors and it s symbol is,

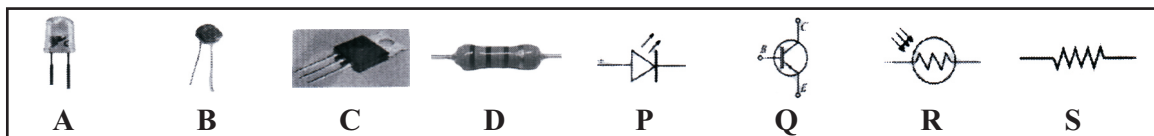

- (I) A and Q (ii) B and R (iii) C and P (iv) D and S

34. Select the incorrect statements about human menstrual cycle,
- (I) At the first 14 days of the menstrual cycle oestrogen hormone is released from the ovary.
 - (ii) Oestrogen hormone level is high at the last 14 days of the menstrual cycle.
 - (iii) There is no effect of the oestrogen hormone in the proliferation phase of the uterus.
 - (iv) There is an effect of progesterone hormone for the secretory phase of menstrual cycle.

35. Given below is a setup arranged using acidic KMnO_4 to investigate the factors affecting the rate of chemical reaction.

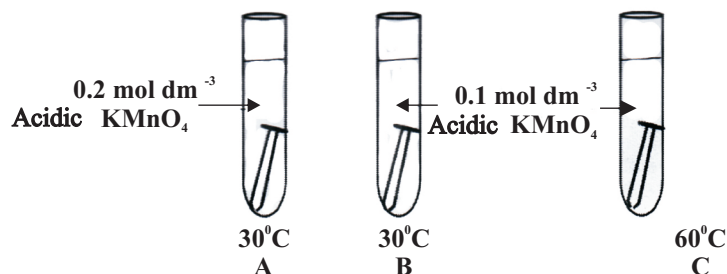

When the above setups are arranged according to the increasing order of time taken to decolorize KMnO_4 , the answer is,

- (I) A B C
- (ii) A C B
- (iii) C A B
- (iv) C B A

36. The graph shows the motion of a mechanical wave. Select the answer which shows the symbols of amplitude, wave length and frequency in order is,

- (I) a b c
- (ii) a b f
- (iii) b c d
- (iv) d e f

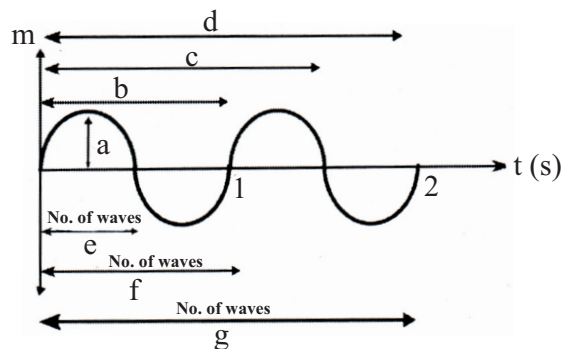

37. The punett square includes the genotypes received by self pollination between the heterozygous genotypes of long leaves . The most suitable genotypes for X and Y are,

- (I) LL and ll
- (ii) ll and Ll
- (iii) Ll and Ll
- (iv) LL and Ll

X	L	l
L	LL	x
l	y	ll

38. A disease which spread among public at present due to change in the life style and preventing from natural food habits is,

- (I) Non Communicable diseases
- (ii) Hereditary diseases
- (iii) Deficiency diseases
- (iv) Mental disorders

39. The statements you considered as results for the productivity of light emitting diodes than other bulbs to illuminate houses are

- (a) Amount of electricity wasted is relatively low.
- (b) The prices of the accessories are very low.
- (c) Life time is relatively high

The most correct statement / statements are ,

- (I) a only
- (ii) b only
- (iii) a and b only
- (iv) a and c only

40. Statement : - With aging, ability of body to respond the stimuli becomes less.

Reason :- Worn out nerve cells can be repaired again.

Answer No.	Stament	Reason
(I)	Correct	Correct
(ii)	Correct	Incorrect
(iii)	Incorrect	Correct
(iv)	Incorrect	Incorrect

- iii. (a) What is the most abundant element in charcoal → (1 mark)
- (b) Name an industry which can launch by using the product of burning charcoal.
 (1 mark)

(c) A sketch diagram of a hoist used to lift vehicles in motor vehicle service station is shown in the figure.

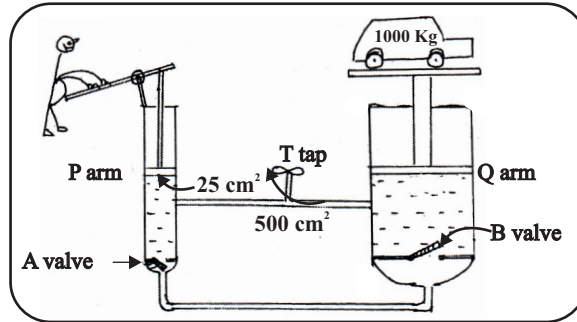

- i. What is the principle in pressure you learnt which is helped in activating the hoist → (1 mark)
- ii. What is the use of the tap named as T → (1 mark)
- iii. The movement of B valve is upward or downward when vehicle is lowered → (1 mark)
- iv. The area of the piston in P arm is 25cm^2 and area of the piston in Q arm is 500cm^2 Find the force that should be applied to raise a vehicle of mass 1000kg.
 (2 marks)

02. (A) Given below is some information about the structure of certain living cell

- Having a cellulose cell wall.
- Having a central vacuole

- I. Which type of cell is described above → (1 mark)
- ii. Name a cell organelle which was limited to above type of cell.
 (1 mark)
- iii. Name the organelles doing the below functions.
 (a). Protein synthesis (1 mark)
 (b). Water balance and turgidity (1 mark)
- iv. What is the cell division method which contributes to form variations → (1 mark)
- v. Name 02 types of cells which form the phloem tissue of plants
 (1 mark)

(B) Organisms are classified for the easiness of study.

- (I). Name the two methods of classing organisms

 (2 marks)

- (ii) Write the animal group to which the following invertebrate animals belong.
- (a). Sea anemone (1mark)
- (b). Neris (1mark)
- (iii) Name the flowing plant group to which the plants having reticulate venation belong (1mark)
- (iv) What is the main function of plant leaves→..... (1 mark)
- (v) Write the balanced chemical equation related to the above mentioned process. (1mark)

(3) (A) Salt solution is a compound commonly used in the laboratory . Salt and water are the components of it.

- (i) Write the chemical formulae of water and salt.
- Salt (1mark)
- Water (1mark)
- (ii) Out of the above components which component has ionic bonds→..... (1mark)
- (iii) Draw the component molecule which is polarized due to the electro negativity .show the relevant poles.



(B) Above solutes and solvents were mixed together.

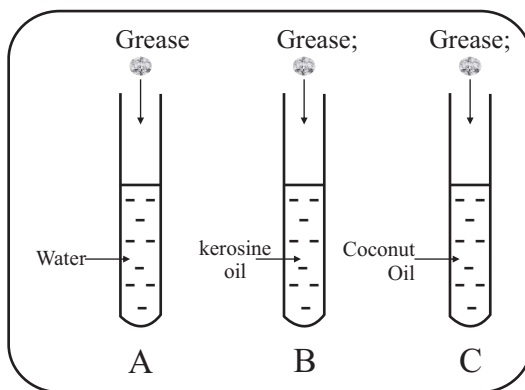

- (i) What is the homogeneous mixture which can be seen after 05minutes → (1mark)
- (ii) Which type of solvent is the grease according to polarity →..... (1mark)
- (iii) In 30 °C ,20g of sugar is completely dissolved in 400g of water. How much is the solubility of sugar in that temperature, (1mark)

(C) (I) Fill in the blanks.

$$\text{Relative molecular mass} = \frac{\text{(a)}}{\frac{1}{12} \times \text{(b)}} \quad (2 \text{ marks})$$

(ii) Find the relative molecular mass of sulphuric acid (H_2SO_4) (S-32,H-1,O-16)

.....
..... (2 marks)

(D) (i) Mention the method used to separate mixtures in each instance .

(a) Separating stones from rice (1mark)

(b) Separating pigments in a toffee (1mark)

(ii) Write an example for a substance which separate using steam distillation

..... (1mark)

04 (A) The above diagram illustrates an instance of motion of a glass ball of mass 400g on the surface of the AB slanted railing. Glass ball is moving with an acceleration along the railing .

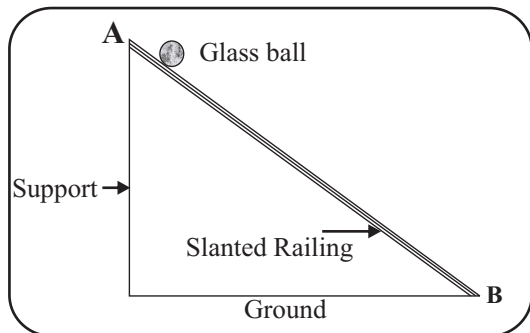

(i) Which Newton's law can be used to explain the motion of the glass ball →

..... (1mark)

(ii) What is the mass of the glass ball ($g=10ms^{-2}$)

..... (2marks)

(iii) State an other force acting on the glass ball except its weight .

..... (1mark)

(iv) At A ,the glass ball started its motion from rest and within 4S it increased its velocity to $10ms^{-1}$.Find the acceleration of the object .

.....
..... (2marks)

(v) Find the unbalanced force acting on the glass ball

.....
..... (2marks)

(B) A sound is produced when the glass ball is rolling on the railing.

(i) As which type of wave, the sound wave produced here is propagated →

..... (1mark)

(ii) Draw a sketch diagram to show the particles in the medium of the wave exists in the wave types you mentioned above (I)

..... (1mark)

(C) Observer could see the glass ball rolling on the railing because of light .

(i) Which type of wave is the light wave →

..... (1mark)

(ii) Name 02 other types of waves including to that category mentioned above and write one

Part B

05) (A). The following pie chart shows the elements that contribute to form the living matter.

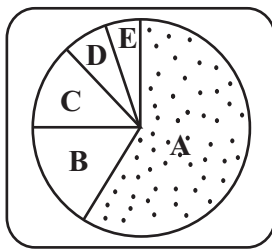

- (i) Name the elements denoted by A, B, and C (3 marks)
- (ii) State two biological molecules containing only C, H and O. (2 mark)
- (iii) What is the term used to introduce the proteins which act as catalysts of biochemical reactions ? (1 mark)
- (iv) Name other elements present in enzymes other than the elements C, H and O (1 mark)

(B) A rough sketch of a cell of a certain muscle tissue present in animals is given below.



- (I) To which type of muscle tissue does this muscle cell belong? (1 mark)
- (ii) State one feature not present in this tissue but present in other types of muscle tissues. (1mark)
- (iii) State 2 locations of the body in which this muscle tissue is present. (2 marks)
- (iv) Name the type of muscle tissue, which contains several nucleoli and a large number of mitochondria.? (1 mark)
- (v) What is the type of tissue, which is responsible for the irritability in organisms? (1mark)

(C) Plants are classified as flowering plants and non – flowering plants in plant classification.

- (i) State the two ways of classifying non-flowering plants (2 marks)
- (ii) Give one example for each of the above two types (2 marks)
- (iii) State one advantage and one disadvantage of tissue culture (2 marks)

(6) (A) Colourless lime water becomes white colour after several days of applying it on a wall.

- (i) What is the chemical substance that causes for becoming the wall white colour? (1 mark)
- (ii) When forming lime water, water is added to calcium oxide. (CaO) State the balanced chemical equation for the above reaction. (2 marks)
- (iii) To which type of chemical reaction , does it belong (1 mark)
- (iv) Name a metal that can be used to displace Cu in a CuSO_4 Solution. (1 mark)
- (v) Mention the methods used for extracting following metals. (1 mark)
 - (a) Iron
 - (b) Gold
 - (c) Sodium
- (vi) Name a gas that can be produced in to school laboratory using chemical decomposition reaction and name a chemical substance that can be used for that purpose. (2 marks)

(B) Three arrangements used to study the rate of reaction of Zn, using 20g of zinc powder to A,B,C test tubes is given below.

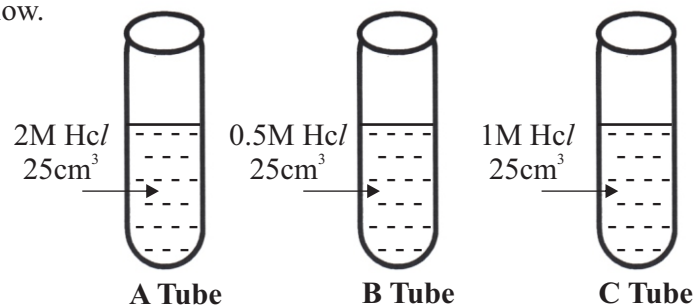

- (i) State the ascending order of the rate of reaction above using letters A,B,C (2 mark)
- (ii) Which factor affecting the rate of reaction is going to be tested here? (2 mark)
- (iii) State one factor that is kept constant during the above experiment (1 mark)
- (iv) What is the term used to introduce the substances which help to increase the rate of reaction without wasting? (2 mark)

- (C) (i) How many moles of NaOH is present in 250ml of NaOH solution with concentration 0.5mol dm^{-3} (2 marks)
- (ii) Calculate the concentration of the solution formed by taking 250ml of the above solution and diluting it with 500 ml of distilled water. (2 marks)

(07) The below diagram shows an instance of using tube to remove water from a fish tank.

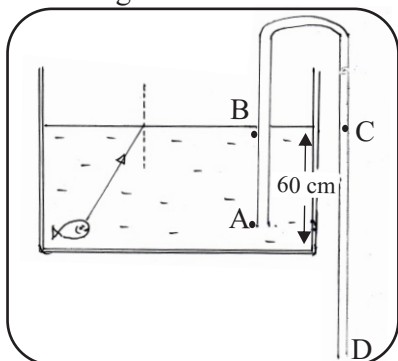

- (A) When observing the fish at the bottom of the tank from the top in air, the fish is seen as raised.
- Which phenomenon of light caused for seeing the fish as raised (2 marks)
 - What is the dense medium when considering water and air (1 mark)
 - Draw the ray diagram of the light ray to denote how the fish in water is seen to the observer E. (2 marks)
 - Mark the angle of incidence "i" and angle of refraction "r" in the diagram you drew in (iii) (2 marks)
 - Write an expression including refractive index of the medium, relevant to the Snell's law of refraction of light , in the instance (iii) (2 marks)
- (B) A tube is submerged to remove water from the fish tank as shown in the figure ($g = 10\text{ ms}^{-2}$)
- State 2 requirements needed to start flowing water from A to D through the tube. (2 marks)
 - Name the points which possess equal pressure from the points A, B, C, D (1 mark)
 - What is the pressure exerted by water on point A? (Density of water = 1000 kgm^{-3}) (2 marks)
 - State what happens to the rate of releasing water in following instances. (increase/ decrease/no change)
 - Increasing the sinking depth of terminal A
 - Reducing the level of water in the tank
 - Increasing the length of C-D (3 marks)
 - The D terminal of the tube is situated 80cm above the ground. Calculate the velocity gained by a water drop when it contacts with the ground falling from the terminal D. (2 marks)
 - The equipment which provides oxygen to the fish tank was connected to the 12v electric supply. If a current of 0.04 A is flowing through it, calculate the resistance of the equipment.(2 marks)
- (8) (A) The building unit of matter is the atom. Molecules are formed due to bonds between atoms. By polymerization of molecules, biological molecules are formed. A number of such biological molecules are present in organisms.
- Name two biological molecules you studied. (2 marks)
 - State one special property in water which facilitate existence in life (1 mark)
 - A sweet taste is felt, sometime after chewing rice in the mouth.
 - What is the disaccharide cause sweet taste in that instance? (1 mark)
 - Name the enzyme that converts rice into that disaccharide (a) (1 mark)
- (B) Sub cellular structures present in the cells of organisms transfer characteristics from generation to generation.
- What is the sub cellular structure that transfers characteristics in organisms? (1 mark)

- (ii) How many chromosome are present in a sperm cell of human? (1 mark)
- (iii) A student noted dominant tall character as TT and recessive short character as tt. State the phenotypic denoted by Tt. (1 mark)
- (iv) (a) Name an inheritant disease that can be transmitted due to marriage between blood relatives. (1 mark)
- (b) Name a field in which the gene technology is used. (1 mark)

(C) A number of cells together forms a tissue. Tasks could be done easily due to that.

- (i) Explain briefly “a meristematic tissue” (2 marks)
- (ii) State a feature present in sclerenchyma tissue but not present in parenchyma and collenchyma tissues. (1 mark)
- (iii) State one function performed by the xylem tissue and the phloem tissue. (2 marks)

(D) Two light rays falling on a certain type of mirror is shown in the diagram.

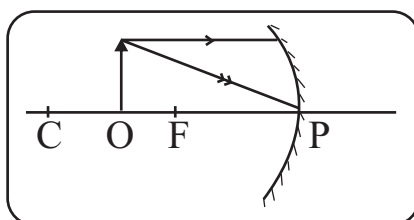

- (i) What type of curved mirror is this ? (1 mark)
- (ii) According to the information given, draw the reflected rays on the answer script. (2 marks)
- (iii) Which law of light reflection was used to draw above reflected rays. (1 mark)
- (iv) State one instance, in which this type of mirrors are used practically. (1 mark)

09 (A) Atomic numbers of some arbitrary elements are given in the table. (They are not Standard symbols)

Arbitrary element	A	B	C	D	E	F	G	H
Atomic number	1	2	3	4	5	6	7	8

- I. According to the structure of the atom, what is the term used to introduce locations, in which electrons are abundantly found? (1 mark)
- II. Draw and represent the position of electrons in element G. (2 marks)
- III. Complete following table in your answer script using above arbitrary elements. (3 marks)

Arbitrary element	Period	Group
B		
E		
H		

- IV. Which element possesses the lowest first ionization energy from C and F (1 mark)
- V. Name an element which forms an acidic oxide from the above elements. (1 mark)
- VI. If the element F contains 10 neutrons, state the element F in standard way (2 marks)

(B) The following figure shows dragging an object of weight 100kg, by 2 men on a flat straight path. The person A, drags the box by a force of 150N to the front. The person B, pushes box towards, the same direction by the force of 50N

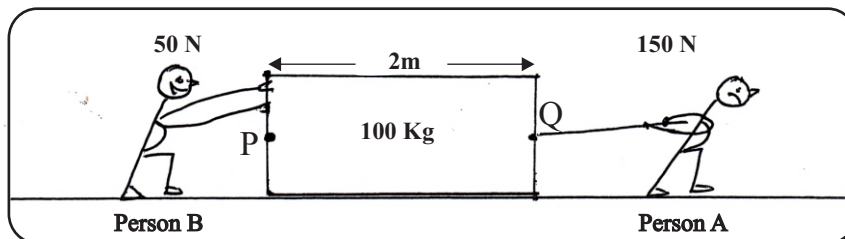

- II. What is the term used to introduce the force created between the ground and the bottom of the box acting against the relative motion of the object? (1 mark)
- II. The force created at the moment of starting the motion is known as..... (static, limiting, dynamic) friction. (1 mark)
- III. According to the information given in the figure,
- (a) Draw the forces acting when moving the box (1 mark)
- (b) What is the resultant force acting? (1 mark)
- (c) Which type of force system is this? (1 mark)
- IV. (a) This box is made to rotate from point P. A force of 150 N is acting from Q perpendicular to the direction as above. Calculate the moment of force in that instance. (2 marks)
- (b) State one change that can be done to reduce the force needed to rotate around point P. (The place where the force Q acting should not be changed) (1 mark)
- (V) Name two forces acting on the box, when that box is rest on the ground (2 marks)

First Term Test - 2018
Science - Grade 11
Marking Scheme

01 - 4	11 - 3	21 - 3	31 - 1
02 - 3	12 - 1	22 - 2	32 - 1
03 - 3	13 - 1	23 - 2	33 - 2
04 - 1	14 - 2	24 - 2	34 - 3
05 - 3	15 - 2	25 - 3	35 - 4
06 - 4	16 - 4	26 - 1	36 - 2
07 - 2	17 - 1	27 - 4	37 - 3
08 - 1	18 - 3	28 - 3	38 - 1
09 - 3	19 - 4	29 - 2	39 - 4
10 - 2	20 - 4	30 - 1	40 - 2

(01)

- A. I. Sexual 1
 ii. Blue lily / Begonia / Kadupul 1
 iii. To write a different between sexual reproduction and asexual reproduction. 1
 iv. Tissue Culture 1
 v. Pollen cells / ovules 1
- B. i. Lustre / Hardness like a property of metal 1
 ii. Litmus test / Phenolphthalein test 1
 Red litmus turn blue / Pink colour.
 The test should be accordance with colour change. 1
 iii. (a) Carbon 1
 (b) production of fizzy drinks / production of dry
 ice / Extinguishing fire / Bakery industry 1
- (i) Transmission of pressure 1
 (ii) Lowering the vehicle 1
 (iii) Downwards 1
 (iv) $\frac{500\text{cm}^2}{25\text{cm}^2} = \frac{10000\text{N}}{5000\text{N}}$ x 1
 1

(02)

- A. (i) Plant cell 1
 (ii) Chloroplast 1
 (iii) (a) ribosome 1
 (b) Vacuole / central vacuole 1
 (iv) Mitosis 1
 (v) Sieve tube / Companion cells / fibre / parenchyma two of the above 2
- B. (i) Natural classification 1
 Artificial Classification 1
 (ii) (a) Cnidaria / Coelenterata 1
 (b) Annelida / Segmented worms 1
 (iii) Dicotyledonae plants / Dicot plants 1
 (iv) Production of food / Photosynthesis 1
 (v) $6\text{CO}_2 + 6\text{H}_2\text{O} \rightarrow \text{C}_6\text{H}_{12}\text{O}_6 + 6\text{CO}_2$ 2
 equation - 1
 for
 balancing - 1

03.			
A.(i)	Salt - NaCl		1
	Water - H ₂ O		1
(ii)	Salt - NaCl		1
(iii)	To show the polarization of water molecule		2
B.(i)	B / Kerosene - Grease tube		1
(ii)	Non polar solvent		1
(iii)	5g		1
C. (i)	a=Mass of a certain molecule		1
	b = Mass of the carbon a atom		1
(ii)	2H +15 +40		1
	2x1+ 1x32+ 4x16		
	98		1
D.(i)	(a) Mechanical method - sifting of winnowing		1
	(b) chromatography		1
(ii)	Cinnamon oil / Rampe/ curry leaf oil/ alcohol		1
04.			
A.(i)	Second Law of Newton		1
(ii)	400gx10ms ⁻²		1
	4N		1
(iii)	Friction force / air resistant force / Perpendicular reaction.		1
(iv)	$\frac{10\text{ms}^{-1}}{45}$		11
	2.5ms ⁻²		1
(v)	400g		1
	1000x2.5ms ⁻²		1
	1N		1
B.(i)	As longitudinal waves		1
(ii)	To represent the position of particles		1
C.(i)	Electromagnetic Waves		1
(ii)	Destroy cancer cells/ sterilization / Detect cracks in concrete		
	X-rays	- Taking photographs of internal body/ checking baggages	
	Ultraviolet	- Production of vitamin D/ Checking currency notes / Kill germs	4
	Micro waves	- Radar system / Mobile phones / micro - wave oven	
	Radio waves	- Transmission of radio communication / television transmission	
		2 answers like above	
05.			
A.(i)	A - Oxygen		1
	B - Carbon		1
	C - Hydrogen		1
(ii)	Glucose / Fructose / Galactose / Maltose / Lactose/ Sucrose/ Starch / Glycogen / Cellulose (2 answer like above)		2
(iii)	Enzyme		1
(iv)	Nitrogen		1
B.(i)	Smooth muscle cell		1
(ii)	Non - Striated		1
(iii)	Stomach / bladder / uterus/ diaphragm (2 answer like above)		2
(iv)	Striated muscle / skeletal muscle		2
(v)	Nervous tissue		

C.(i)	Seeded plants	1
	Seedless plants	1
(ii)	Example for seeded plant	1
	Example for seedless plant	1
(iii)	Advantage - Can obtain large number of plants which are identical to the mother plant.	1
(iv)	Disadvantage - Cannot practice for all plants / Expensive / Less laboratory facilities	1
06.		
A.(i)	Calcium Carbonate	1
(ii)	$\text{CaO} + \text{H}_2\text{O} \longrightarrow \text{Ca}(\text{HO})_2$ Necessary to denote physical state	2
(iii)	Chemical combination reactions	1
(iv)	Magnesium / zinc / Iron like metal which is present above Ca in activity series	1
(v)	(a) Reduction / Heating in air	1
	(b) Physical methods (Sifting, Riple method, using amalgam)	1
	(c) Electrolysis	1
(vi)	Oxygen gas - Heating Condys / decompositions of Hydrogen peroxide	1
	Cabondioxide - Heating calcium carbonate	2
B.(i)	B, C, A	
(ii)	Concentration	
(iii)	Temperature / Volume/ Mass	
(iv)	Catalysts	
C.(i)	<u>Co n</u>	
	$0.5 \text{ mol dm}^{-3} = n \frac{\quad}{250\text{cm}^3} \quad n = 0.125 \text{ mol}$	
(ii)	$\frac{0.125 \text{ mol}}{0.5\text{dm}^3} = 0.25 \text{ moldm}^{-3}$	
07.		
A.(i)	Refraction of light	1
(ii)	Water	1
(iii)	To draw the ray diagram	2
	Away from the normal - 1	
	Rising the fish - 1	
(iv)	Denoting the angle of incidence	1
	Denoting the ray refraction -	1
(v)	$\frac{\sin i}{\sin r} = \frac{n_2}{n_1}$	2
	for correct sine ratio -1	
	for correct refractive index - 1	
B.(i)	Presence of a pressure difference / Presence of water level above the tube / filling the tube with water (2 answer like above)	2
(ii)	B, D points	1
(iii)	$\frac{60\text{cm}}{100} \times 1000\text{kgm}^{-3} \times 10\text{ms}^{-2}$	1
	600Nm ⁻² 01 6000 Pa	1
(iv)	(a) No Change	1
	(b) Reduce / decrease	1
	(c) Increase	1
(v)	$M = \frac{80\text{cm}}{100} \times 10\text{ms}^{-2} = 1/2 \times m \times V^2$	1
	$V = 4\text{ms}^{-2}$	1
(vi)	$V = IR$ 12V = .04A x R	1
	R = 300Ω	1

- 08.
- A. (i) Carbohydrates / Proteins / Lipids/ Nucleic acid (for 2 answers) 2
(ii) Universal solvent / high boiling point / high expansion / adhesives and cohesive forces / high specific heat capacity (for 1 property) 1
(iii) (a) Maltose 1
(b) Amylase / Ptylin 1
- B. (i) Chromosome 1
(ii) 23 1
(iii) Tall / Heterozygous tall 1
(iv) (a) Thalassaemia 1
(b) Agriculture / Animal husbandry / Medical field / Forensic medicine 1
- C. (i) A group of cell which have the ability to form new cells and occurring mitosis actively 2
(ii) Sclerenchyma cells are non living 1
(iii) Xylem - Transport water and minerals / Mechanical strength 1
Phloem - Translocation of food / Mechanical strength 1
- D. (i) Concave mirror 1
(ii) To draw one reflected ray accurately (1m) for two accurate rays 2
(iii) Snell's Law. Second Law of reflection of light 1
(iv) Shaving / Examine the mouth and teeth / telescopes 1
- 09.
- A. (i) Energy Levels / Shells 1
(ii) A figure containing electrons as 2,8,2 2
(iii)
- | Arbitrary element | Period | Group |
|-------------------|--------|-------|
| B | 1 | viii |
| E | 2 | iv |
| H | 3 | v |
- (iv) C 1
(v) C or D 1
(vi) 18 F 2
8
- B. (i) Frictional force 1
(ii) Limiting 1
(iii) (a) For accurate figure with forces 1
(b) 200N 1
(c) collinear force system 1
- (iv) (a) 2m x 150N 1
300Nm 1
(b) Increasing the length of the box / Applying lubricant to the bottom 1
- (v) Weight
Perpendicular reaction.